

POWERQUAD™ PNEUMATIC VACUUMS OPERATING INSTRUCTIONS

FOR STANDARD, NED, ATEX, PULSEAIR™
& DUST EXTRACTOR MODELS



GUARDAIR®

guardair.com

TABLE OF CONTENTS

| | |
|--|-----------|
| Introduction | 3 |
| Vacuum Descriptions | |
| Standard Vacuums | 4 |
| NED Vacuums | 4 |
| ATEX Vacuums | 4 |
| ATEX Certification | 4 |
| PulseAir Vacuums & Dust Extractors | 5 |
| Set-up and Operation | 5 |
| First Time Set-up | 5 |
| All Vacuums | 5 |
| PulseAir Vacuums | 5 |
| Dolly Assembly | 6 |
| Vacuum Drums | 6 |
| Compressed Air Supply | 6 |
| Changing Injector Nozzles | 6 |
| Grounding the Vacuum | 9 |
| Operation | 10 |
| Wet Vacuum | 10 |
| PulseAir Vacuums and Dust Extractors | 11 |
| Maintenance | 12 |
| General Maintenance | 12 |
| Filters | 12 |
| Cover Gaskets | 13 |
| Silencer Foam | 15 |
| Reverse Flow Check Valve | 16 |
| Second Stage Venturi Shut Off Valve | 18 |
| Accessories and Spare Parts | 19 |
| Frequently Asked Questions | 20 |
| Product Schematics | 22 |
| Warranties | 37 |

Welcome to a New Era in Pneumatic Vacuum Technology!

Thank you for purchasing a Guardair PowerQUAD™ Vacuum. Powered by compressed air, PowerQUAD Vacuums deliver superior vacuum performance while saving energy. Featuring a revolutionary, patent-pending, 2-stage, multi-venturi design, these units generate unparalleled vacuum head and vacuum flow while consuming up to 71% LESS compressed air. This translates into more thorough and effective cleaning, and significant cost savings in compressed air and labor. In addition, PowerQUAD Vacuums are 10 – 15 dBA quieter than conventional vacuums and operate at 88 dBA or less.

Perhaps the most innovative feature is PowerQUAD's customer-configurable performance. Three color-coded, easy-to-change injector nozzle sets are optimized for three progressive levels of performance and compressed air savings. Simply remove the rear manifold, select a nozzle set, and screw them in.

With a rugged, diecast aluminum vacuum-generating engine and sleek, compact profile, PowerQUAD Vacuums are available in 5, 10, 20, 30 and 55 gallon models. Both wet and dry applications are covered as all PowerQUAD models come standard with a liquid shutoff device.

PowerQUAD Vacuums are completely interchangeable with existing Guardair vacuums as they use the same drums, covers, vacuum attachments and accessories. PowerQUAD Vacuum Generating Heads can easily be swapped out in the field with any existing Guardair Vacuum Generating Head.

Plant safety is another important reason to choose a pneumatic vacuum. Intrinsically safe PowerQUAD Vacuums run exclusively on standard plant compressed air, with no electric motor to produce sparks, or no electric power cords. This makes them perfect for wet environments and hazardous locations. To meet these needs, PowerQUAD Vacuums are also available in NED (Non-Electrical Discharge) and ATEX certified versions. PowerQUAD technology is also incorporated into Guardair PulseAir Vacuums & Dust Extractors which are ideal when paired with source-capture tools or within high dust applications.



VACUUM DESCRIPTIONS

VACUUM MODELS

POWERQUAD STANDARD VACUUMS

PowerQUAD Standard Vacuums are ideal for a wide range of industrial and commercial applications where static electricity is generally not a concern. Under some conditions, all vacuums (pneumatic and electric) have the potential to generate static electricity caused by certain materials passing through the vacuum hose. Should static electric charges be of concern, end-users should consider switching to PowerQUAD NED (Non-Electrical Discharge) or ATEX vacuums.

POWERQUAD NED VACUUMS

PowerQUAD NED (Non-Electrical Discharge) Vacuums are designed to eliminate nuisance shocks from static electricity by incorporating static conductive components to suppress static electricity charges. Should stray static charges become generated, these charges are immediately dissipated through electrically interconnected, static conductive components.

For an added measure of static electricity dissipation NED Vacuums can be grounded.

See **GROUNDING THE VACUUM**

IMPORTANT

PowerQUAD NED Vacuums are designed to eliminate nuisance static electricity. They are not certified for use in hazardous locations. Utilize only PowerQUAD ATEX Vacuums for hazardous locations.

POWERQUAD ATEX VACUUMS

PowerQUAD ATEX Vacuums are designed to operate in hazardous locations by controlling and dissipating potentially dangerous static electricity charges.

To ensure electrical conductivity, ATEX Vacuums feature steel, aluminum and conductive plastic components and accessories. Metal-to-metal contact between the cover and the container is provided through the braided grounding strap. Static conductive vacuum hose eliminates static electricity generation caused by material passing through the vacuum hose.

Electrically grounding ATEX Vacuums is also required to ensure that all static electricity charges are fully dissipated.

See **GROUNDING THE VACUUM**

IMPORTANT
ATEX VACUUMS MUST BE PROPERLY
GROUNDED TO ENSURE SAFE OPERATION.

ATEX CERTIFICATION

Currently no US standards exist to certify non-electrically powered equipment, such as pneumatic vacuums, for safe use in hazardous locations. However, Europe has adopted such standards and they are known as ATEX Directives. Guardair engaged Sira Certification Service of the UK to certify that PowerQUAD Hazardous Location Pneumatic Vacuums meet the applicable ATEX Directives. After a comprehensive evaluation, SIRA Certification Service certified PowerQUAD ATEX 30 & 55 Gallon Vacuums with the following rating:



II 2GD

Exh IIC T6 Gb

Exh IIIC T85°C Db

*** Equivalent to National Fire Protection Association 70: NEC Rating:**

Class I Division 1** Groups A, B, C, D T6

Class II Division 1 Groups E, F, G T6

Class III

** Zone 1 only

VACUUM DESCRIPTIONS

POWERQUAD PULSEAIR™ VACUUMS & DUST EXTRACTORS

PowerQUAD PulseAir Vacuums & Dust Extractors incorporate proprietary PulseAir technology engineered to clean the internal vacuum filter without routinely opening the unit. By activating the PulseAir System, a burst of compressed air is injected into the interior of the filter mounted beneath the vacuum lid. Dust particles clogging the outer filter surface are dislodged and settle within the closed container. Benefits include limiting worker exposure to dusty, dirty filters, as well as dramatically extended filter life.

In addition to automatic filter cleaning, PulseAir Vacuums & Dust Extractors are equipped with HEPA filtration to comply with OSHA Silica Dust Regulation 29 CFR 1926.1153. They also include a cloth pre-filter bag to provide enhanced filter protection

and extend filter life. All PulseAir Vacuums & Dust Extractors come standard with static conductive components to eliminate nuisance shocks.

PowerQUAD PulseAir Vacuums are ideal for applications with high levels of dust and small debris. They also excel where filters tend to clog frequently, causing interruptions in cleanup.

PowerQUAD Dust Extractors are designed for point-of-source dust collection applications or source capture power tools. These units come equipped with a vacuum hose to connect directly to the dust port outlet of a power tool.

For an added measure of static electricity dissipation, PulseAir Vacuums & Dust Extractors can be grounded.

See **GROUNDING THE VACUUM**

SET-UP AND OPERATION

FIRST TIME SET-UP

FOR ALL VACUUMS

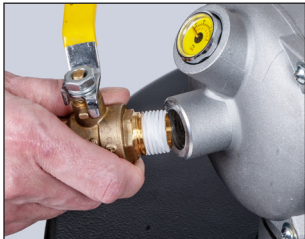

1. Install the ball valve onto the PowerQUAD Vacuum Generating Engine. Use Teflon tape or thread sealant on the threads of the ball valve.



2. Install the vacuum hose adapter into the inlet elbow. If needed use a rubber mallet to tap the adapter into the inlet elbow.



3. Connect the vacuum hose to the vacuum hose adaptor. Connect desired attachment to the other end of the vacuum hose.

FOR PULSEAIR VACUUMS & DUST EXTRACTORS



1. Install the 1/2" pipe nipple into the inlet of the ball valve. Use Teflon tape or thread sealant on the threads on both ends of the pipe nipple.

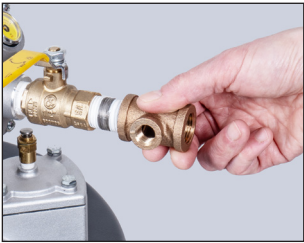

2. Install the 1/2" to 1/4" pipe tee reducer onto the pipe nipple. Orientate the 1/4" outlet of the pipe tee to the same side of the manifold with the 1/4" push-to-connect elbow installed.

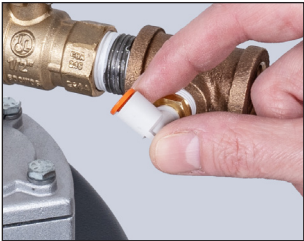

3. Install the 1/4" push-to-connect elbow into the 1/4" outlet of the tee. Use Teflon tape or thread sealant on the threads of the elbow.

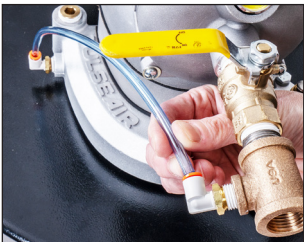

4. Install the 1/4" OD tubing into both push-to-connect elbows. Ensure the tubing is fully seated in the fitting. A slightly added resistance will be felt before the tube is fully seated. Once fully seated, test the connection by firmly pulling on the tube. It should stay locked in the fitting.

SET-UP AND OPERATION

DOLLY ASSEMBLY

Assemble the 55, 30 & 20 Gallon Drum Dolly as shown below:

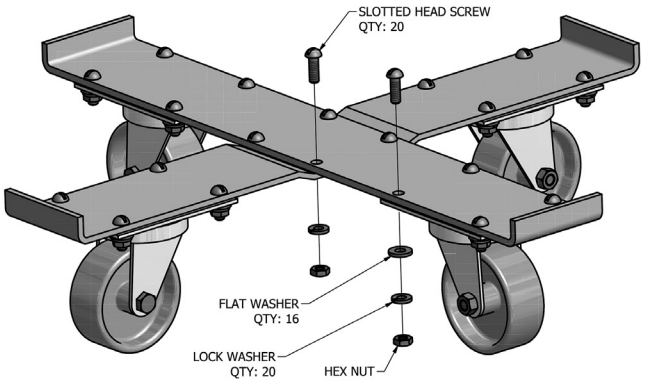

VACUUM DRUMS

CAUTION

Drums used with Power QUAD Vacuum Generating Heads must meet or exceed the steel gauge requirements in the table below. Thinner gauges of steel run the risk of drum collapse. Note that the lower gauge number, the thicker the steel.

| DRUM | 55 gal | 30 gal | 20 gal | 10 gal | 5 gal |
|-------------|--------|--------|--------|--------|-------|
| GAUGE STEEL | 19 | 18 | 18 | 20 | 20 |

COMPRESSED AIR SUPPLY

FOR YOUR SAFETY

Disconnect compressed air connections only after the compressed air supply has been turned off and the air supply hose vented by opening the valve on the vacuum generating engine. NEVER disconnect a pressurized compressed air hose.

An adequate supply of compressed air is essential for the proper performance of PowerQUAD Vacuums. Compressed air requirements for the injector nozzle sets are listed below:

- Green Injector Nozzles** 20 cfm
- Blue Injector Nozzles** 40 cfm
- Yellow Injector Nozzles** 60 cfm

Note that these requirements are for compressed air volume, not pressure. The recommended compressed air inlet static operating pressure is 100 psi for all vacuum units. All units will function at lower operating pressures, but with a corresponding reduction in performance. Consequently, the pressure gauge should read between 80 psi and 90 psi during operation for an optimally operating vacuum. If the pressure is lower than 80 psi and the vacuum performance is inadequate, install lower flowing nozzles. **TABLE A** outlines vacuum performance based upon vacuum hose size and shows compressed air usage for each injector nozzle color.

1/2" ID or larger compressed air hose is recommended for Yellow and Blue Injector Nozzles. 3/8" ID or larger compressed air hose is recommended for Green Nozzles. Use of a smaller diameter air hose will restrict performance.

CHANGING INJECTOR NOZZLES

PowerQuad Vacuums come with three (3) sets of injector nozzles that allow users to change vacuum performance. Users can optimize vacuum performance based on how much compressed air they have available.

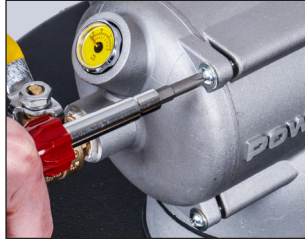

1. Remove the four manifold screws.



4. Install new nozzles using a 5/8" socket. Finger tight will suffice.

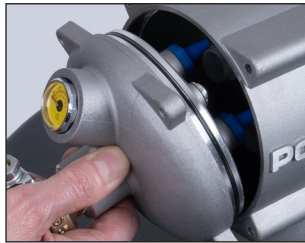

2. Remove the manifold. Gently rotating the manifold left and right while pulling the manifold out of the body may be needed.



5. Inspect the o-ring on the manifold. Clean and apply o-ring lubrication if needed. Replace the o-ring if needed.

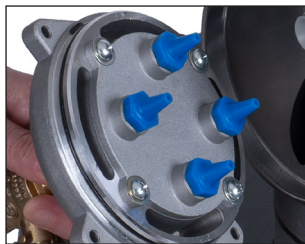

3. Remove injector nozzles using a 5/8" socket.



6. Re-insert the manifold ensuring the o-ring remains in the o-ring groove. First, insert the bottom of the manifold into the body, and then slowly push the top of the manifold fully into the body.



7. Reinstall the manifold screws. Tighten until snug, then 1/4" to 1/2" additional turns.

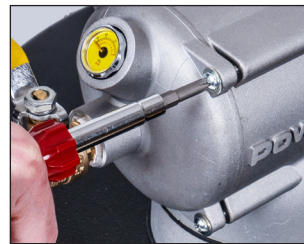

SET-UP AND OPERATION

TABLE A POWERQUAD VACUUM PERFORMANCE SPECIFICATIONS

| GREEN INJECTOR NOZZLES | 1-1/4" ID x 10' Vacuum Hose 3/8" ID x 12' Air Supply Hose | | 1-1/2" ID x 10' Vacuum Hose 1/2" ID x 12' Air Supply Hose | | 2" ID x 10' Vacuum Hose 1/2" ID x 12' Air Supply Hose | |
|--|--|-----|--|-----|--|-----|
| | Air Usage (cfm) | 20 | Air Usage (cfm) | 20 | Air Usage (cfm) | 20 |
| | Max Vac Flow (cfm) | 75 | Max Vac Flow (cfm) | 92 | Max Vac Flow (cfm) | 110 |
| | Max Vac Head (inches H2O) | 118 | Max Vac Head (inches H2O) | 126 | Max Vac Head (inches H2O) | 122 |
| | Max Power (Air Watts) | 202 | Max Power (Air Watts) | 226 | Max Power (Air Watts) | 213 |
| | Max Noise Level (dBA) | 83 | Max Noise Level (dBA) | 82 | Max Noise Level (dBA) | 85 |
| BLUE INJECTOR NOZZLES | 1-1/4" ID x 10' Vacuum Hose 3/8" ID x 12' Air Supply Hose | | 1-1/2" ID x 10' Vacuum Hose 1/2" ID x 12' Air Supply Hose | | 2" ID x 10' Vacuum Hose 1/2" ID x 12' Air Supply Hose | |
| | Air Usage (cfm) | 35 | Air Usage (cfm) | 40 | Air Usage (cfm) | 40 |
| | Max Vac Flow (cfm) | 92 | Max Vac Flow (cfm) | 118 | Max Vac Flow (cfm) | 139 |
| | Max Vac Head (inches H2O) | 184 | Max Vac Head (inches H2O) | 225 | Max Vac Head (inches H2O) | 215 |
| | Max Power (Air Watts) | 309 | Max Power (Air Watts) | 425 | Max Power (Air Watts) | 459 |
| | Max Noise Level (dBA) | 81 | Max Noise Level (dBA) | 85 | Max Noise Level (dBA) | 86 |
| YELLOW INJECTOR NOZZLES | 1-1/4" ID x 10' Vacuum Hose 3/8" ID x 12' Air Supply Hose | | 1-1/2" ID x 10' Vacuum Hose 1/2" ID x 12' Air Supply Hose | | 2" ID x 10' Vacuum Hose 1/2" ID x 12' Air Supply Hose | |
| | Air Usage (cfm) | 60 | Air Usage (cfm) | 60 | Air Usage (cfm) | 60 |
| | Max Vac Flow (cfm) | 97 | Max Vac Flow (cfm) | 129 | Max Vac Flow (cfm) | 149 |
| | Max Vac Head (inches H2O) | 213 | Max Vac Head (inches H2O) | 251 | Max Vac Head (inches H2O) | 250 |
| | Max Power (Air Watts) | 341 | Max Power (Air Watts) | 588 | Max Power (Air Watts) | 667 |
| | Max Noise Level (dBA) | 86 | Max Noise Level (dBA) | 83 | Max Noise Level (dBA) | 88 |

NOTE:

GREEN INJECTOR NOZZLES are factory installed in all vacuums with 1-1/4" ID vacuum hose inlets.

BLUE INJECTOR NOZZLES are factory installed in all vacuums with 1-1/2" or 2" ID vacuum hose inlets.

GROUNDING THE VACUUM

POWERQUAD NED VACUUMS

POWERQUAD PULSEAIR VACUUMS

POWERQUAD PULSEAIR DUST EXTRACTORS

Users may choose to electrically ground PowerQUAD NED Vacuums and PowerQUAD PulseAir Vacuums & Dust Extractors to provide an added measure of static electricity dissipation. It is important to understand that simply grounding these units does not make them suitable for hazardous locations. Regardless, the three (3) grounding options are the same as described below for PowerQUAD ATEX Vacuums.

POWERQUAD ATEX VACUUMS

To operate PowerQUAD ATEX Vacuums safely in approved hazardous locations, the vacuum must be properly grounded during operation.

Prior to operating the vacuum ensure all conductive parts of the vacuum are properly bonded. Inspect the unit and replace worn or broken components. Use only original Guardair replacement parts.

To ensure proper electrical bonding (connectivity between conductive components), make sure that only static conductive, factory-supplied parts and accessories are used. Inspect all static conductive vacuum components before use and replace worn, broken or rusted parts as needed. All components must fit together firmly, including the static conductive vacuum hose, which must mount securely on the vacuum hose inlet. All static conductive vacuum accessories must fit securely on the end of the vacuum hose.

Proper grounding of PowerQUAD ATEX Vacuums can be achieved in one of three (3) ways:

1. Through a Static Conductive Air Supply Hose

This option utilizes a static conductive air supply hose to connect the vacuum to a compressed air distribution system that is electrically grounded. Only use this method if the compressed air distribution system has been verified to be fully grounded.



2. Through the Vacuum Lid Grounding Lug

This option utilizes a direct electrical connection from the grounding lug on the vacuum cover to a nearby, verified electrical ground (electrical cabinet, grounding rod, cold water pipe, etc.).



3. Operating the Vacuum on an Electrically Grounded Surface

This option provides conductivity from the vacuum directly to an electrically grounded surface (steel floor plate, concrete ground level floor, etc.). The container of the vacuum can rest on the grounded surface directly, or on the dolly since the container, dolly frame, and dolly wheels are all steel. Only use this method if the surface is electrically grounded, and only when a continuous electrical connection between the vacuum and the grounded surface can be verified and maintained.



NOTE: EMPLOYING MULTIPLE, REDUNDANT GROUNDING OPTIONS IS ALWAYS SOUND OPERATING PRACTICE.

IMPORTANT

IT IS THE RESPONSIBILITY OF THE USER TO ENSURE PROPER CONNECTION TO AND THE ELECTRICAL INTEGRITY OF THE GROUND.

If you have questions about the methodology and necessity for grounding, consult a qualified Electrical Engineer.

SET-UP AND OPERATION

OPERATION

Prior to operating the vacuum, inspect the unit and replace worn or broken components. Use only original Guardair replacement parts.

See **ACCESSORIES AND SPARE PARTS**

1. Inspect bottom side of the vacuum lid to ensure filter is held securely in place by the wingnut.
2. Make sure top lip of vacuum drum is flat and dent free. Check gasket on the underneath side of vacuum lid.



3. Place vacuum generating head on top of vacuum drum.



4. Ensure ball valve on vacuum is in **OFF** position. Connect compressed air supply hose to ball valve on the unit.
5. Connect compressed air supply hose to the plant compressed air system.



6. Turn compressed air supply **ON**. Inspect compressed air hose for air leaks.

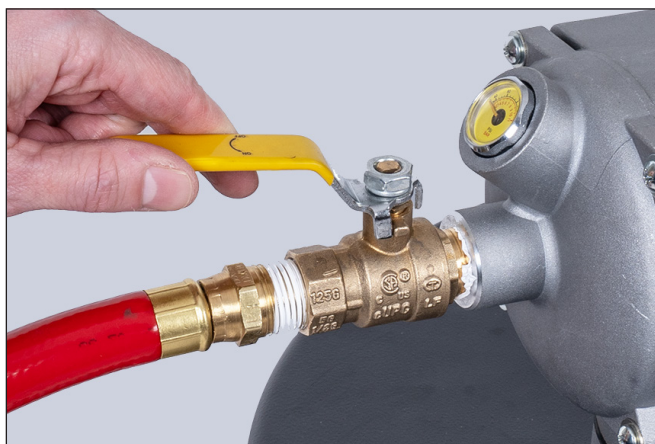

7. Open ball valve on vacuum to operate. Pressure gauge should read between 80 psi and 90 psi during operation for an optimally operating vacuum. If pressure is lower than 80 psi and the vacuum performance is inadequate, install lower flowing injector nozzles.

See **CHANGING INJECTOR NOZZLES**

WET VACUUM

All PowerQUAD Vacuums come equipped with a liquid shutoff assembly. Before picking up liquids, remove the cartridge filter. Leave the wire cage coalescing sleeve in place.



POWERQUAD PULSEAIR VACUUMS & DUST EXTRACTORS

PulseAir Vacuums and Dust Extractors incorporate a proprietary, button-activated, pneumatic system engineered to clean the vacuum filter from the inside out without opening the unit. When a reduction in vacuum performance is noted, pulse the filter as shown below:



1. Turn the vacuum to **OFF**. Ensure all four (4) lid clamps are secured.



2. Actuate the pulse by momentarily pressing the push button valve. Actuate the pulse 3 to 10 times, waiting 2 seconds between pulses.



3. If pulsing the filter no longer improves performance, remove and clean pre-filter bag and filter. Alternatively, replace with new pre-filter bag and/or filter.

See **ACCESSORIES AND SPARE PARTS**

MAINTENANCE

GENERAL MAINTENANCE

Inspect the vacuum periodically and replace worn or broken components. Use only original Guardair replacement parts.

See **ACCESSORIES AND SPARE PARTS**

FILTERS

Check the internal filter periodically. Ensuring maximum performance means cleaning the filter when it becomes dirty and/or clogged. Over time, even regularly cleaned filters lose their effectiveness as the pores in the filter media fill up. Therefore, regular filter replacement should be a part of an effective maintenance plan.

To clean or replace the filter:



1. Remove the pre-filter bag if needed. Regular pre-filter bags slip over the filter and are secured in place with an elastic hem. PulseAir pre-filter bags are secured in place with a worm-gear clamp.

2. Inspect the pre-filter bag and worm-gear clamp. Replace if damaged or worn.



3. Remove the wingnut and sealing washers at the bottom of the filter.



4. Lift the filter off the wire cage frame.



5. Clean the filter by shaking and tapping the filter, or by directing compressed air against the interior surface of the filter. Do not use liquids to clean the filter.



6. Inspect the filter. Immediately replace a damaged, ripped or torn filter.



7. Remove nut and washers holding the wire cage coalescing filter in place.
8. Clean the coalescing filter by shaking, tapping, or with compressed air. The coalescing filter can be cleaned with soap and water.



9. Inspect the wire cage coalescing filter. The main purpose of the coalescing filter is to capture moisture when the vacuum is used during wet applications. However, vacuumed materials may reach the coalescing filter if the internal filter is missing or compromised. Replace if damaged, ripped or torn.
10. With the filter and coalescing filter removed, inspect the wire cage and ball float. Replace if damaged.
11. Installation is the opposite of removal.

IMPORTANT

The filter sealing washer is made from static conductive material. It is essential to reinstall this washer in ATEX Vacuums to electrically bond the filter with the rest of the vacuum.

COVER GASKETS

Replace lid gaskets should they become worn, frayed, or ineffective

55, 30 AND 20 GALLON MODELS



1. Remove the gasket to be replaced by hand.



2. Clean the cover with GooGone or similar cleaning solvent.



3. Peel back approximately 6 inches of the protective backing on the new gasket.

MAINTENANCE



4. Adhere the gasket to the bottom of the cover, working steadily around the cover and removing the protective backing along the way.



5. On 30 & 20-gallon vacuums, be sure to line up the scallop in the gasket with the vacuum exit elbow.



IMPORTANT

It is essential to reinstall the grounding strap on the cover, and around the gasket, for ATEX Vacuums to electrically bond the cover with the rest of the vacuum units.

10 AND 5 GALLON MODELS

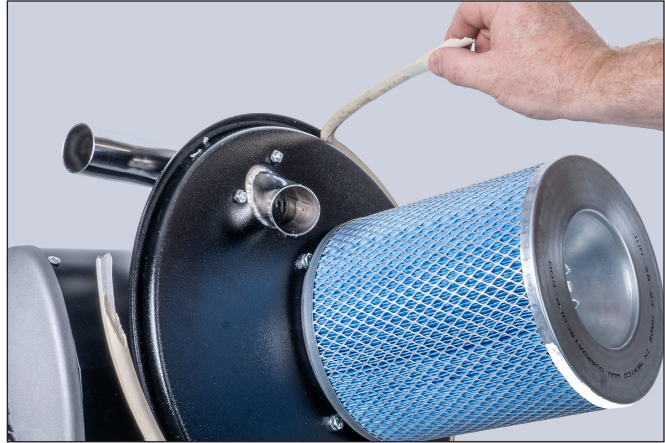

1. Tear old gasket off the vacuum cover



2. Hot Glue is the adhesive type used to bond the gasket to the vacuum cover. To remove dried residual glue, soak surface liberally with rubbing alcohol and allow to sit. Old glue should scrap off easily.



3. Use hot glue to install the new gasket. Lay the gasket in place and lift a starting spot to insert the hot glue nozzle.



4. Work around the vacuum cover dispensing fresh hot glue while pressing the gasket down into the fresh hot glue.



2. Remove the exhaust housing. Then remove the silencer foam.

SILENCER FOAM

Check the silencer foam periodically. The main function of the silencer foam is for sound deadening. However, vacuumed materials may reach and damage the silencer foam if the internal filter is missing or compromised.

To clean or replace silencer foam:



1. Remove the three (3) screws securing the exhaust housing.



3. Remove the wire cage coalescing filter by sliding it over the venturi diffusers

4. Clean the silencer foam by shaking, tapping, or with compressed air. They can be cleaned with soap and water.

5. Inspect and replace if damaged, ripped or torn.

6. Installation is the opposite of removal.

MAINTENANCE

REVERSE FLOW CHECK VALVE

PowerQUAD PulseAir Vacuums and Dust Extractors have a reverse flow check valve located under the vacuum cover, on the exit of the vacuum outlet elbow.



1. Remove the vacuum cover and flip it over.



2. Inspect the reverse flow check valve. It should move freely. Replace if damaged, ripped or torn.



3. To replace, remove the reverse flow check valve by removing the worm-gear clamp.



4. When installing the new reverse flow check valve, position the valve over the outlet elbow so that the flap is flush with the outlet elbow exit

5. Tighten the worm-gear clamp.

SECOND STAGE VENTURI SHUT OFF VALVE

PowerQUAD vacuum generating engines have two venturi stages. Depending on vacuuming demand, the second stage is automatically closed off by the Second Stage Venturi Shut Off Valve. The valve should be periodically checked to ensure free operation.



1. Remove the vacuum cover and flip it over.



2. Remove the prefilter bag if needed. Regular prefilter bags slip over the filter and are secured in place with an elastic hem. PulseAir prefilter bags are secured in place with a worm-gear clamp.



3. Remove the wingnut and sealing washers at the bottom of the filter.

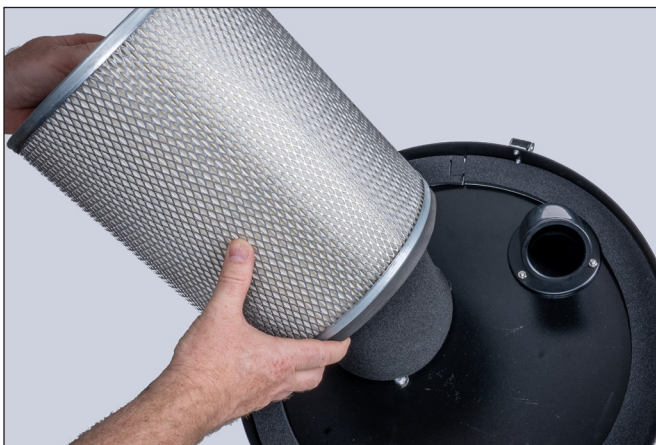

4. Lift the filter off the wire cage frame.



5. Remove nut and washers holding the wire cage coalescing filter in place.



6. Removing the filter and coalescing filter provides access to the Second Stage Venturi Shut off Valve through the hole in the cover. Inspect and ensure it moves freely. If it does not move freely, or if the shut off valve is damaged, ripped or torn, follow the next steps for replacing.



7. Remove the three hex head bolts holding the PowerQUAD head to the cover.

MAINTENANCE

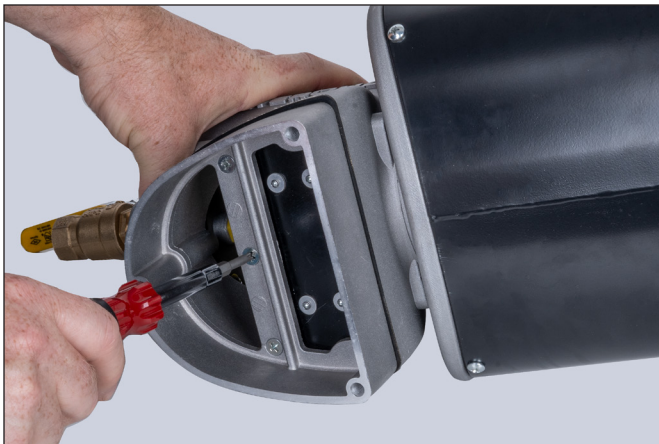

8. Remove the 3 flat head screws securing the vacuum generating engine base.



9. Remove valve.



10. Clean the gasket surfaces on the base and vacuum generating engine.

11. Installation is the opposite of removal.

ACCESSORIES AND SPARE PARTS

| PART NUMBER | PRODUCT DESCRIPTION |
|-------------|---|
| PQ635 | PowerQUAD Standard Filter |
| PQ635PK | PowerQUAD Standard Filter 6-Pack |
| PQ635H | PowerQUAD HEPA Filter w/ Pre-Filter Bag |
| PQ635U | PowerQUAD ULPA Filter w/ Pre-Filter Bag |
| PQ803 | PowerQUAD Injector Nozzle Set (3 Sets of 4 Nozzles) |
| PQ801 | PowerQUAD Second Stage Venturi Shut-Off Valve |
| PQ805 | PowerQUAD Air Pressure Gauge |
| PQ686 | PowerQUAD Silencer Foam |
| PQ685 | PowerQUAD Exhaust Housing w/ Silencer Foam |
| PQ901 | PowerQUAD 5/10 Gallon Liquid Shut-Off Assembly |
| PQ637F | PowerQUAD 5/10 Gallon Wire Cage Coalescing Filter |
| PQNMK10 | PowerQUAD 5/10 Gallon Maintenance Kit |
| PQ905K | PowerQUAD 5/10 Upgrade/Retrofit Kit |
| PQNMK30 | PowerQUAD 20/30 Gallon Maintenance Kit |
| PQ204 | PowerQUAD 20/30 Gallon Push Dolly |
| PQ638 | PowerQUAD 20/30/55 Gallon Liquid Shut-Off Assembly |
| PQ638F | PowerQUAD 20/30/55 Gallon Wire Cage Coalescing Filter |
| PQ638K | PowerQUAD 20/30/55 Gallon Liquid Shut-Off Assembly Upgrade/Retrofit Kit |
| PQ900K | PowerQUAD 20/30/55 Upgrade/Retrofit Kit |
| PQNMK55 | PowerQUAD 55 Gallon Maintenance Kit |
| PQ554 | PowerQUAD 55 Gallon Push Dolly |
| 38X12GP | General Purpose Air Hose Assembly - 3/8" ID X12' |
| 38X25GP | General Purpose Air Hose Assembly - 3/8" ID X 25' |
| 38X50GP | General Purpose Air Hose Assembly - 3/8" ID X 50' |
| 38X12SC | Static Conductive Air Hose Assembly - 3/8" ID X 12' |
| 38X25SC | Static Conductive Air Hose Assembly - 3/8" ID X 25' |
| 38X50SC | Static Conductive Air Hose Assembly - 3/8" ID X 50' |
| 12X12GP | General Purpose Air Hose Assembly - 1/2" ID X 12' |
| 12X25GP | General Purpose Air Hose Assembly - 1/2" ID X 25' |
| 12X50GP | General Purpose Air Hose Assembly - 1/2" ID X 50' |
| 12X12SC | Static Conductive Air Hose Assembly - 1/2" ID X 12' |
| 12X25SC | Static Conductive Air Hose Assembly - 1/2" ID X 25' |
| 12X50SC | Static Conductive Air Hose Assembly - 1/2" ID X 50' |
| PQ685 | PowerQUAD Exhaust Housing w/ Silencer Foam |
| PQ686 | PowerQUAD Silencer Foam |
| PQNVGA | PowerQUAD Vacuum Generating Engine |
| N656 | Gasket For 55 Gallon Cover |
| N657 | Gasket For 5/10 Gallon Cover |
| N650 | 55 Gallon Steel Drum |
| N650ATEX | 55 Gallon ATEX Steel Drum |
| N630 | 30 Gallon Steel Drum |
| N630ATEX | 30 Gallon ATEX Steel Drum |
| N050 | 5 Gallon Canister Assembly |
| N100 | 10 Gallon Canister Assembly |
| N200 | 20 Gallon Canister Assembly |
| N12510 | 1.25" X 10' Standard Duty Vinyl Vacuum Hose |
| N67010 | 2" X 10' Standard Duty Vinyl Vacuum Hose |
| N69110 | 1.5" X 10' Standard Duty Vinyl Vacuum Hose |
| N652 | 2" X 10' Standard Duty PVC Static Conductive Vacuum Hose |
| 2100A02NED | 1.5" X 10' Standard Duty Static Conductive Hose |

To order or see the full line of PowerQUAD Accessories and Spare Parts, visit guardair.com or your local Guardair Distributor.

FREQUENTLY ASKED QUESTIONS

TECHNICAL

How do PowerQUAD compressed air-powered vacuums work?

Compressed air-powered vacuums (also known as pneumatic vacuums) work on the venturi principle. Compressed air, via the compressed air supply hose, enters the venturi box and travels through the injector nozzle. As the air continues through the surrounding venturi, it accelerates, thereby creating low pressure inside the venturi box. This low pressure induces vacuum flow inside the adjacent canister, and in turn through the attached vacuum hose.

What are the advantages of compressed air-powered vacuums over electric vacuums?

Compressed air-powered vacuums offer a number of significant advantages over electric vacuums. These include:

- (1) Compressed air-powered vacuums have no electric motor to wear out or burnout. Motor failure most often occurs in high demand applications where a motor is strained for long periods of time, for example when vacuuming heavy liquids or operating with a clogged filter.
- (2) With no electric motor, sparking at the brushes is eliminated, and no electric fields are present. This is important in hazardous locations, for example when combustible fumes are present.
- (3) Compressed air-powered vacuums require no dangerous, high voltage electric cords. Over time cords often become frayed as they are dragged across shop floors, or run over by mobile equipment, such as carts or forklift trucks. This is an important safety feature particularly on steel surfaces or where floors are wet.
- (4) Compressed air-powered vacuums generate significantly more vacuum lift than electric vacuums. This enables them to suck up heavier materials a higher vertical distance.
- (5) Compressed air is often more readily available than electric power in most in-plant and many remote or mobile locations.
- (6) And finally, since compressed air-powered vacuums feature an unlimited lifespan, their Total Cost of Ownership (TCO) is often lower than equivalent electric vacuums.

What is the difference between Vacuum Flow and Vacuum Lift?

Vacuum Flow is the volume of air that passes through a vacuum hose during a given period of time. Vacuum flow is expressed in cubic feet per minute (cfm). With any given diameter vacuum hose, the higher the vacuum flow, the higher the air velocity traveling through that vacuum hose, and the more effective the vacuum unit will be at sucking up and transporting debris.

Vacuum Lift is the height that a vacuum unit can raise a given material or liquid. Vacuum lift (sometimes referred to as vacuum head) is expressed in inches of mercury (in Hg), or inches of water (in H₂O). Thus, a vacuum with a rating of 120 inches of water can suck up water from a tank buried 120 inches (10 feet) underground.

What is the definition of 'Vacuum Suction'?

Vacuum suction is a non-scientific term referring to the general cleaning power of a vacuum unit. Vacuum suction is an off-hand way to describe a vacuum unit's ability to generate vacuum flow, vacuum lift, and its overall effectiveness to clean.

With respect to compressed air, what is the difference between Pressure and Flow?

Pressure is the measure of potential energy stored within compressed air. Pressure is measured in pounds per square inch (psi). The higher the pressure, the more energy is stored, and the more work can be performed. In general, most industrial compressed air systems operate at pressures between 80 and 120 psi. The electrical equivalent of pressure is voltage. **Flow** is the volume of air traveling through an air supply line, or through a vacuum hose, during a given period of time. Flow is measured in cubic feet per minute (cfm). The electrical equivalent of flow is amperage.

How do vacuums generate static electricity?

Both electric and compressed air-powered vacuums have the potential to generate static electricity. Static electricity is generated by the movement of air over the internal surface of a vacuum hose. The amount generated is a function of the composition and humidity of the air, air velocity, vacuum hose material, and material being vacuumed.

OPERATION AND MAINTENANCE

What size (capacity) air compressor do I need to operate my PowerQUAD vacuum?

A good rule of thumb states that air compressors generate approximately 4 cubic feet per minute (cfm) of compressed air per horsepower (HP) on a continuous basis. For example, a 50 HP air compressor will generate approximately 200 cfm (4 x 50) on a continuous basis. Refer to the specifications on your air compressor for more information. For a given injector nozzle set, the table below shows the minimum size air compressor required (when run continuously) to supply compressed air to the vacuum.

| Injector Nozzle Set (color) | Compressed Air Consumption (cfm) | Minimum Compressor Size (HP) |
|-----------------------------|----------------------------------|------------------------------|
| Green | 20 | 4.4 |
| Blue | 40 | 8.9 |
| Yellow | 60 | 13.3 |

FREQUENTLY ASKED QUESTIONS

How do I optimize the performance of my PowerQUAD Vacuum?

PowerQUAD vacuums can be configured to maximize compressed air savings, maximize vacuum performance, or a balance between the two. PowerQUAD vacuums come with three (3) sets of injector nozzles, all of which provide industry leading vacuum efficiency (vacuum performance per cfm of compressed air consumed). To maximize compressed air savings, install the lowest flowing injector nozzles (Green) and then test the vacuum. If higher vacuum performance is desired, install the next higher flowing injector nozzles (Blue) and test again. To maximize vacuum performance, install highest flowing injector nozzles (Yellow) and test the vacuum.

If PowerQUAD vacuum performance is not as expected, the capacity of the compressed air system may not be sufficient. With the vacuum running, check the pressure gauge which should read between 80 and 90 psi. If the gauge measures lower than 80 psi, considering installing lower flowing injector nozzles.

Since vacuum performance is directly related to compressed air consumption, make sure the air supply hose is delivering adequate compressed air to the vacuum for a given injector nozzle set. Refer to **TABLE A** for compressed air consumption, vacuum performance specifications, and recommended minimum size of the compressed air supply line.

What is the recommended operating air pressure for my PowerQUAD vacuum?

Most in-plant air compressors operate at pressures, or are regulated to between 80-120 psi. PowerQUAD vacuum are engineered to offer optimal performance at 80-90 psi as read on the pressure gauge located on the rear manifold of the vacuum while the vacuum is running.

What size compressed air supply line do I need to run my PowerQUAD vacuum?

PowerQUAD vacuums require compressed air supply lines that range from 3/8" ID up to 1/2" ID depending upon the injector nozzles that have been installed within the vacuum generating head. Refer **TABLE A** for recommended compressed air supply line size. To ensure adequate performance, a larger than required air supply line can always be employed, but never a smaller size.

What about connectors and fittings?

Be sure that fittings and/or connectors do not restrict the air supply flow in any manner. Use fittings that are rated the same size, or larger, for a given air supply line. For optimal operation, use "High Flow" connectors.

How does the size of my compressed air receiver size in combination with my air compressor effect vacuum performance?

Receiver size can also affect the operation of the vacuum. The larger the receiver, the longer the period of time the vacuum can run without calling upon the air compressor to cycle "on" and refill the receiver.

Can I use any steel drum with my PowerQUAD vacuum generating head?

No. PowerQUAD vacuum generating heads produce extremely high head. Generating vacuum lift of up to 255 inches of H₂O running on 80-90 psi of compressed air, they have been known to implode. Therefore, Guardair recommends that steel drums meet the following necessary wall thickness:

| DRUM | 55 gal | 30 gal | 20 gal | 10 gal | 5 gal |
|--------------------|--------|--------|--------|--------|-------|
| GAUGE STEEL | 19 | 18 | 18 | 20 | 20 |

What is the maximum ambient temperature in which I can operate my PowerQUAD vacuum?

150° F

How often do I need to replace the filter and/or Silencer Foam?

Filters should be inspected regularly. Shake out and clean, or replace, clogged filters. Immediately replace ripped or torn filters. Silencer foam should also be inspected regularly and does not normally need to be replaced unless dust/dirt is getting past the filter. Shake out the foam if covered with dirt/dust and replace if necessary.

Does Guardair also offer HEPA and ULPA filters?

In addition to offering Standard filters, Guardair offers HEPA and ULPA filters for PowerQUAD Vacuums.

Why does my PowerQUAD vacuum seem to have inadequate suction?

By far the most common problem is undersized compressed air supply lines, or restrictions due to undersized fittings and/or connectors. Some combination of these two issues often results in inadequate compressed air being supplied to the vacuum. When the vacuum is operating, the pressure gage should read between 80 and 90 psi. If the pressure is lower, check for compressed air restrictions. If no restrictions are found, consider changing out the injectors. See **CHANGING INJECTOR NOZZLES**. In addition, other things to look for include low plant compressed air pressure (less than 80 psi), a dirty filter, a clogged vacuum hose, or a leaky vacuum head gasket.

What is the definition of "Air Watts"?

Air Watts are a measure of a vacuum's suction power and is a function of Vacuum Flow (cfm) and Vacuum Lift (inches H₂O). The higher the Air Watt rating, the better the vacuum performance. Published Air Watt ratings for PowerQUAD Pneumatic Vacuums also account for air resistance within filters and vacuum hose to provide an accurate measurement of their actual suction power.

PRODUCT SCHEMATICS

VACUUM GENERATING HEAD

| Item No. | Part No. | Description |
|----------|----------|------------------------|
| 1 | N900H12* | SCREW |
| 2 | N906X02* | GASKET BASE |
| 3 | PQ801 | VALVE ASSEMBLY |
| 4 | N900X02* | BODY |
| 5 | N901X01* | SMALL VENTURI |
| 6 | N902X01* | INJECTOR NOZZLE |
| 7 | N900A02* | MANIFOLD ASSEMBLY |
| 8 | N900H08* | WASHER |
| 9 | N900H07* | SCREW |
| 10 | PQ805 | PRESSURE GAGE |
| 11 | N910X01* | LARGE VENTURI INLET |
| 12 | N908X02* | VENTURI BASE |
| 13 | N900H06* | SCREW |
| 14 | N909X01* | LARGE VENTURI DIFFUSER |
| 15 | N900H05* | COALESCING FILTER |
| 16 | N900H01* | SOUND DEADENING FOAM |
| 17 | N900A04* | EXHAUST HOUSING |

Items (*) are not sellable on their own.

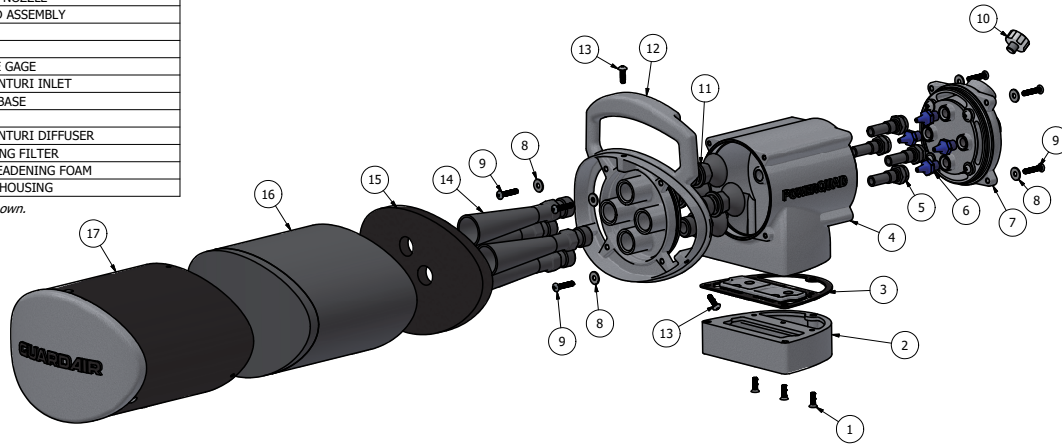

| Replacement Kits & Maintenance | | |
|--------------------------------|----------|----------------------------------|
| Item No. | Part No. | Description |
| 6 | PQ803 | INJECTOR NOZZLE SET |
| 15 & 16 | PQ686 | SILENCER FOAM |
| 15 - 17 | PQ685 | EXHAUST HOUSING W/ SILENCER FOAM |

5 GALLON VACUUM KIT WITH 1.25" INLET

| Item No. | Part No. | Description |
|----------|------------|---|
| 1 | PQNVGA | VACUUM GENERATING HEAD (SEE FIGURE 1) |
| 2 | 2000H14* | BRASS BUSHING 1/2 NPT MALE X 3/8 NPT FEMALE |
| 3 | N851* | 3/8 MALE X FEMALE NPT BALL VALVE, BRASS |
| 4 | N682 | GASKET FOR VENTURI BOX |
| 5 | N053W* | COVER WELDMENT FOR 5 & 10 GAL |
| 6 | N053Q-1* | GASKET, DRUM COVER, 5 & 10 GAL |
| 7 | N6271* | 1/4 INTERNAL TOOTH LOCK WASHER |
| 8 | N900H23* | FLOAT ONLY, FOR LIQUID SHUT-OFF |
| 9 | 2000M02-2* | WIRE CAGE COALESCING FILTER |
| 10 | N900H24* | WIRE CAGE COALESCING FILTER |
| 11 | N900H19* | OVERSIZED WASHER 3/8 |
| 12 | N600H2* | HEX NUT, SS, 3/16-16, 18-8 |
| 13 | MV2000F1 | STANDARD FILTER |
| 14 | N6341* | HELICAL SPRING LOCK WASHER |
| 15 | 2000H10* | WING NUT, 3/8"-16 STEEL |
| 16 | N050 | 5 GALLON DRUM ASSEMBLY |
| 17 | N900H17* | HEX CAP SCREW, ZINC PLTD |
| 18 | N12510 | 1-1/4" X 10' STD. DUTY VACUUM |
| 19 | 38X12GP | 3/8" X 12' AIR SUPPLY HOSE |
| 20 | N849 | PLASTIC CREVICE TOOL, 9" LONG |
| 21 | N843 | PLASTIC 3" ROUND BRUSH TOOL |
| 22 | N845 | 5" WIDE PLASTIC UTILITY TOOL WITH BRUSH |
| 23 | 14VA02 | 19" PLASTIC WAND |

Items (*) are not sellable on their own.

| Replacement Kits & Maintenance | | |
|--------------------------------|----------|---|
| Item No. | Part No. | Description |
| 1, 4, 7, & 17 | PQNVGA | VACUUM GENERATING ENGINE |
| 4, 6, & 13 | PQNMK10 | 5/10 GALLON MAINTENANCE KIT |
| 8 - 12 & 17 | PQ901 | 5/10 GALLON LIQUID SHUT-OFF ASSEMBLY |
| 10 - 12 | PQ637F | 5/10 GALLON WIRE CAGE COALESCING FILTER |

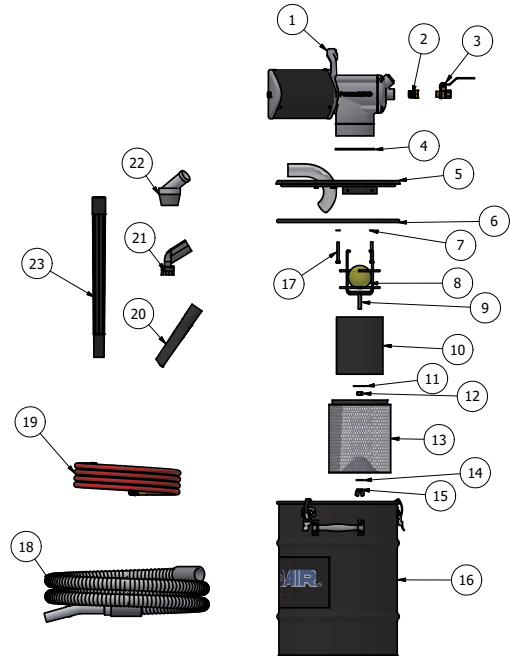

10 GALLON VACUUM KIT WITH 1.25" INLET

| Item No. | Part No. | Description |
|----------|------------|---|
| 1 | PQNVGA | VACUUM GENERATING HEAD (SEE FIGURE 1) |
| 2 | 2000H14* | BRASS BUSHING 1/2 NPT MALE X 3/8 NPT FEMALE |
| 3 | N851* | 3/8 MALE X FEMALE NPT BALL VALVE, BRASS |
| 4 | N682 | GASKET FOR VENTURI BOX |
| 5 | N053W* | COVER WELDMENT FOR 5 & 10 GAL |
| 6 | N053Q-1* | GASKET, DRUM COVER, 5 & 10 GAL |
| 7 | N6271* | 1/4 INTERNAL TOOTH LOCK WASHER |
| 8 | N900H23* | FLOAT ONLY, FOR LIQUID SHUT-OFF |
| 9 | 2000M02-2* | WIRE CAGE COALESCING FILTER |
| 10 | N900H24* | WIRE CAGE COALESCING FILTER |
| 11 | N900H19* | OVERSIZED WASHER 3/8 |
| 12 | N600H2* | HEX NUT, SS, 3/16-16, 18-8 |
| 13 | MV2000F1 | STANDARD FILTER |
| 14 | - | CONDUCTIVE SEALING WASHER (COMES WITH FILTER) |
| 15 | 2000H10* | WING NUT, 3/8"-16 STEEL |
| 16 | N100 | 10 GAL. DRUM ASSEMBLY |
| 17 | N900H17* | HEX CAP SCREW, ZINC PLTD |
| 18 | N12510 | 1-1/4" X 10" STD. DUTY VACUUM |
| 19 | 38X12GP | 3/8" X 12' AIR SUPPLY HOSE |
| 20 | N849 | PLASTIC CREVICE TOOL, 9" LONG |
| 21 | N845 | 5" WIDE PLASTIC UTILITY TOOL WITH BRUSH |
| 22 | N843 | PLASTIC 3" ROUND BRUSH TOOL |
| 23 | 14VA02 | 19" PLASTIC WAND |

Items (*) are not sellable on their own.

| Replacement Kits & Maintenance | | |
|--------------------------------|----------|---|
| Item No. | Part No. | Description |
| 1, 4, 7, & 17 | PQNVGA | VACUUM GENERATING ENGINE |
| 4, 6, & 13 | PQNMK10 | 5/10 GALLON MAINTENANCE KIT |
| 8 - 12 & 17 | PQ901 | 5/10 GALLON LIQUID SHUT-OFF ASSEMBLY |
| 10 - 12 | PQ637F | 5/10 GALLON WIRE CAGE COALESCING FILTER |

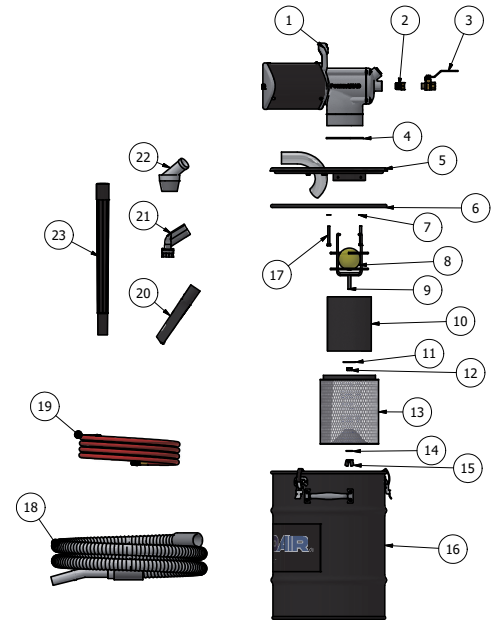

10 GALLON VACUUM KIT WITH 1.5" INLET

| Item No. | Part No. | Description |
|----------|------------|--|
| 1 | PQNVGA | VACUUM GENERATING HEAD |
| 2 | N651 | 1/2 NPT BALL VALVE, BRASS |
| 3 | N682 | GASKET FOR VENTURI BOX |
| 4 | N053W* | COVER WELDMENT FOR 5 & 10 GAL |
| 5 | N053Q-1* | GASKET, DRUM COVER, 5 & 10 GAL |
| 6 | N6271* | 1/4 INTERNAL TOOTH LOCK WASHER |
| 7 | N900H23* | FLOAT ONLY, FOR LIQUID SHUT-OFF |
| 8 | 2000M02-2* | WIRE CAGE COALESCING FILTER |
| 9 | N900H24* | WIRE CAGE COALESCING FILTER |
| 10 | N900H19* | OVERSIZED WASHER 3/8 |
| 11 | N600H2* | HEX NUT, SS, 3/16-16, 18-8 |
| 12 | MV2000F1 | STANDARD FILTER |
| 13 | 2000H10* | WING NUT, 3/8"-16 STEEL |
| 14 | N100 | 10 GAL. DRUM ASSEMBLY |
| 15 | N900H17* | HEX CAP SCREW, ZINC PLTD |
| 16 | N634* | 10-32 UNF-2B HEX NUT, SST |
| 17 | N6341* | HELICAL SPRING LOCK WASHER |
| 18 | N054Q* | GASKET, INLET, 5 & 10 GAL 1.25 |
| 19 | N104* | WELDMENT, INLET, 5 & 10 GAL 1.25 |
| 20 | N050H03* | SCREW, PAN HEAD 10-32 UNF |
| 21 | N692 | FLOOR TOOL W/ WAND - METAL FOR 1.5" HOSE |
| 22 | 12X12GP | 1/2" ID 12' AIR SUPPLY HOSE |
| 23 | 2100A02NED | 1-1/2" X 10' STD. DUTY VAC HOSE |
| 24 | N6931 | ALUM CREVICE TOOL, 11" LONG |

Items (*) are not sellable on their own.

| Replacement Kits & Maintenance | | |
|--------------------------------|----------|---|
| Item No. | Part No. | Description |
| 1, 3, 6, & 16 | PQNVGA | VACUUM GENERATING ENGINE |
| 3, 6, & 12 | PQNMK10 | 5/10 GALLON MAINTENANCE KIT |
| 7 - 11 & 16 | PQ901 | 5/10 GALLON LIQUID SHUT-OFF ASSEMBLY |
| 9 - 11 | PQ637F | 5/10 GALLON WIRE CAGE COALESCING FILTER |

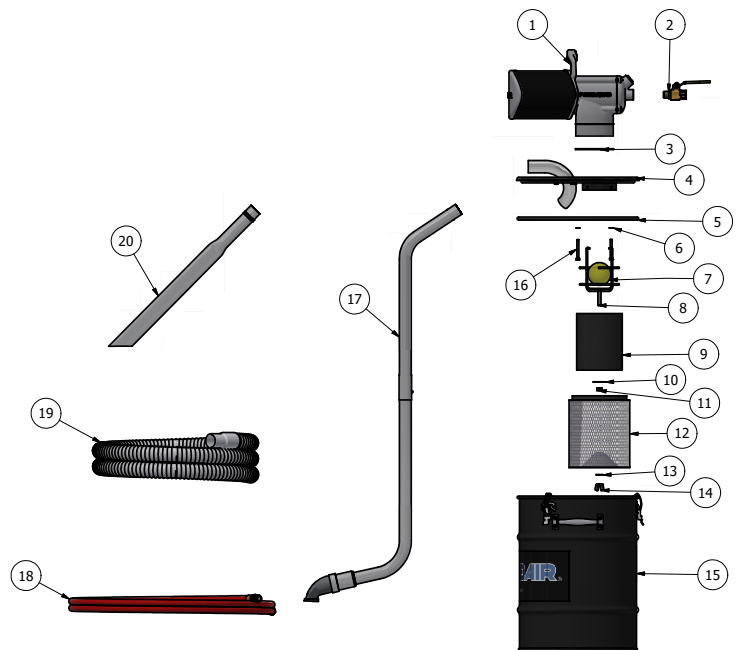

PRODUCT SCHEMATICS

20 GALLON VACUUM KIT WITH 1.5" INLET

| Item No. | Part No. | Description |
|----------|----------|---|
| 1 | PQNVGA | POWERQUAD VACUUM ENGINE (SEE FIGURE 1) |
| 2 | N651 | 1/2 NPT BALL VALVE, BRASS |
| 3 | N682 | GASKET |
| 4 | N900H15* | 20 & 30 GALLON DRUM COVER |
| 5 | N655 | DRUM GASKET |
| 6 | N6271* | WASHER |
| 7 | N900H21* | SCREW |
| 8 | N6381* | BALL FLOAT |
| 9 | N900H18* | WIRE CAGE |
| 10 | N900H20* | WIRE CAGE COALESCING FILTER |
| 11 | N900H19* | WASHER |
| 12 | N600H2* | NUT |
| 13 | PQ635 | STANDARD FILTER |
| 14 | - | CONDUCTIVE SEALING WASHER (COMES WITH FILTER) |
| 15 | 2000H10* | WING NUT |
| 16 | N200 | 20-GALLON STANDARD DRUM |
| 17 | N667 | 20/30-GALLON DRUM DOLLY |
| 18 | N715 | 1-1/2" VACUUM HOSE ADAPTOR |
| 19 | N69110 | 1-1/2" X 10' STANDARD VACUUM HOSE |
| 20 | 12X12GP | 1/2" X 12' STANDARD AIR HOSE |
| 21 | N692 | 1 1/2" FLOOR TOOL |
| 22 | N693 | 24" CREVICE TOOL |

Items (*) are not sellable on their own.

| Replacement Kits & Maintenance | | |
|--------------------------------|----------|---|
| Item No. | Part No. | Description |
| 1, 3, 6, & 7 | PQNVGA | VACUUM GENERATING ENGINE |
| 3 & 5 | PQNMK30 | 20/30 GALLON MAINTENANCE KIT |
| 6 - 12 | PQ638 | 20/30/55 GALLON LIQUID SHUT-OFF ASSEMBLY |
| 10 - 12 | PQ638F | 20/30/55 GALLON WIRE CAGE COALESCING FILTER |
| 13-14 | PQ635H | HEPA FILTER W/ PRE-FILTER BAG |

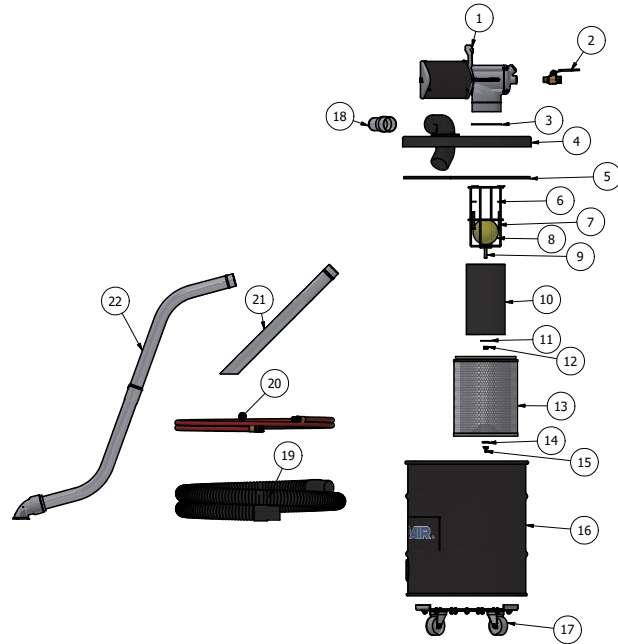

20 GALLON VACUUM KIT WITH 2" INLET

| Item No. | Part No. | Description |
|----------|----------|---|
| 1 | PQNVGA | POWERQUAD VACUUM ENGINE (SEE FIGURE 1) |
| 2 | N651 | 1/2 NPT BALL VALVE, BRASS |
| 3 | N682 | GASKET |
| 4 | N900H15* | 20 & 30 GALLON DRUM COVER |
| 5 | N655 | DRUM GASKET |
| 6 | N6271* | WASHER |
| 7 | N900H21* | SCREW |
| 8 | N6381* | BALL FLOAT |
| 9 | N900H18* | WIRE CAGE |
| 10 | N900H20* | WIRE CAGE COALESCING FILTER |
| 11 | N900H19* | WASHER |
| 12 | N600H2* | NUT |
| 13 | PQ635 | STANDARD FILTER |
| 14 | - | CONDUCTIVE SEALING WASHER (COMES WITH FILTER) |
| 15 | 2000H10* | WING NUT |
| 16 | N200 | 20-GALLON STANDARD DRUM |
| 17 | N667 | 20/30-GALLON DRUM DOLLY |
| 18 | N720 | 2" VACUUM HOSE ADAPTOR |
| 19 | N67010 | 2" X 10' STANDARD VACUUM HOSE |
| 20 | 12X12GP | 1/2" X 12' STANDARD AIR HOSE |
| 21 | N639 | 2" FLOOR TOOL |
| 22 | N693 | 24" CREVICE TOOL |

Items (*) are not sellable on their own.

| Replacement Kits & Maintenance | | |
|--------------------------------|----------|---|
| Item No. | Part No. | Description |
| 1, 3, 6, & 7 | PQNVGA | VACUUM GENERATING ENGINE |
| 3 & 5 | PQNMK30 | 20/30 GALLON MAINTENANCE KIT |
| 6 - 12 | PQ638 | 20/30/55 GALLON LIQUID SHUT-OFF ASSEMBLY |
| 10 - 12 | PQ638F | 20/30/55 GALLON WIRE CAGE COALESCING FILTER |
| 13-14 | PQ635H | HEPA FILTER W/ PRE-FILTER BAG |

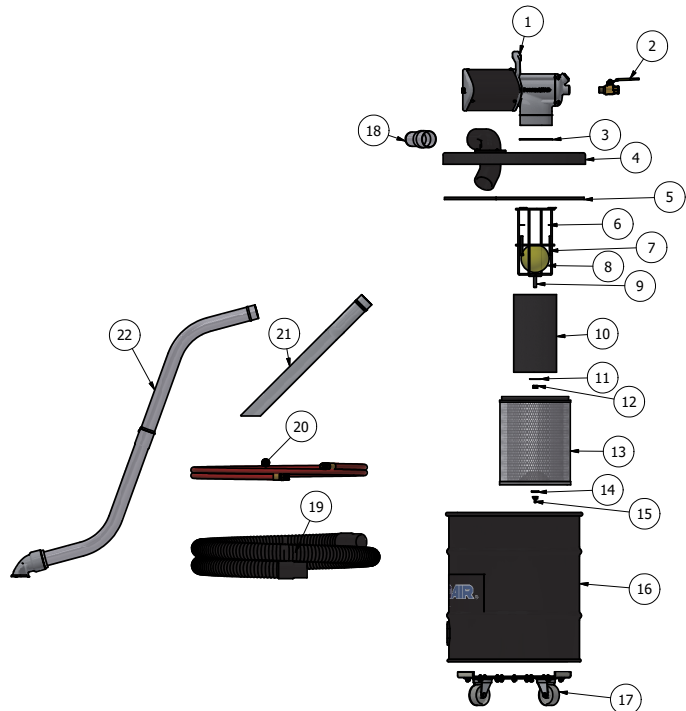

30 GALLON VACUUM KIT WITH 1.5" INLET

| Item No. | Part No. | Description |
|----------|----------|---|
| 1 | PQNVGA | POWERQUAD VACUUM ENGINE (SEE FIGURE 1) |
| 2 | N651 | 1/2 NPT BALL VALVE, BRASS |
| 3 | N682 | GASKET |
| 4 | N900H15* | 20 & 30 GALLON DRUM COVER |
| 5 | N655 | DRUM GASKET |
| 6 | N6271* | WASHER |
| 7 | N900H21* | SCREW |
| 8 | N6381* | BALL FLOAT |
| 9 | N900H18* | WIRE CAGE |
| 10 | N900H20* | WIRE CAGE COALESCING FILTER |
| 11 | N900H19* | WASHER |
| 12 | N600H2* | NUT |
| 13 | PQ635 | STANDARD FILTER |
| 14 | - | CONDUCTIVE SEALING WASHER (COMES WITH FILTER) |
| 15 | 2000H10* | WING NUT |
| 16 | N630 | 30-GALLON STANDARD DRUM |
| 17 | N667 | 20/30-GALLON DRUM DOLLY |
| 18 | N715 | 1-1/2" VACUUM HOSE ADAPTOR |
| 19 | N69110 | 1-1/2" X 10' STANDARD VACUUM HOSE |
| 20 | 12X12GP | 1/2" X 12' STANDARD AIR HOSE |
| 21 | N692 | 1 1/2" FLOOR TOOL |
| 22 | N693 | 24" CREVICE TOOL |

Items (*) are not sellable on their own.

| Replacement Kits & Maintenance | | |
|--------------------------------|----------|---|
| Item No. | Part No. | Description |
| 1, 3, 6, & 7 | PQNVGA | VACUUM GENERATING ENGINE |
| 3 & 5 | PQNMK30 | 20/30 GALLON MAINTENANCE KIT |
| 6 - 12 | PQ638 | 20/30/55 GALLON LIQUID SHUT-OFF ASSEMBLY |
| 10 - 12 | PQ638F | 20/30/55 GALLON WIRE CAGE COALESCING FILTER |
| 13-14 | PQ635H | HEPA FILTER W/ PRE-FILTER BAG |

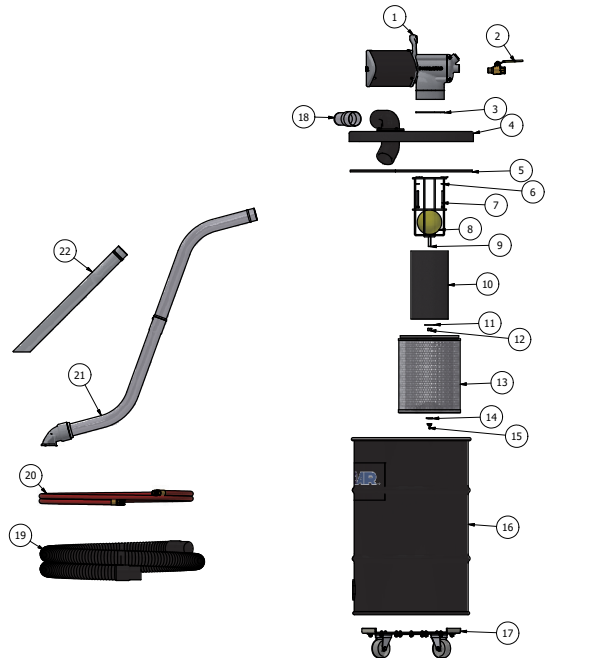

30 GALLON VACUUM KIT WITH 2" INLET

| Item No. | Part No. | Description |
|----------|----------|---|
| 1 | PQNVGA | POWERQUAD VACUUM ENGINE (SEE FIGURE 1) |
| 2 | N651 | 1/2 NPT BALL VALVE, BRASS |
| 3 | N682 | GASKET |
| 4 | N900H15* | 20 & 30 GALLON DRUM COVER |
| 5 | N655 | DRUM GASKET |
| 6 | N6271* | WASHER |
| 7 | N900H21* | SCREW |
| 8 | N6381* | BALL FLOAT |
| 9 | N900H18* | WIRE CAGE |
| 10 | N900H20* | WIRE CAGE COALESCING FILTER |
| 11 | N900H19* | WASHER |
| 12 | N600H2* | NUT |
| 13 | PQ635 | STANDARD FILTER |
| 14 | - | CONDUCTIVE SEALING WASHER (COMES WITH FILTER) |
| 15 | 2000H10* | WING NUT |
| 16 | N630 | 30-GALLON STANDARD DRUM |
| 17 | N667 | 20/30-GALLON DRUM DOLLY |
| 18 | N720 | 2" VACUUM HOSE ADAPTOR |
| 19 | N67010 | 2" X 10' STANDARD VACUUM HOSE |
| 20 | 12X12GP | 1/2" X 12' STANDARD AIR HOSE |
| 21 | N639 | 2" FLOOR TOOL |
| 22 | N693 | 24" CREVICE TOOL |

Items (*) are not sellable on their own.

| Replacement Kits & Maintenance | | |
|--------------------------------|----------|---|
| Item No. | Part No. | Description |
| 1, 3, 6, & 7 | PQNVGA | VACUUM GENERATING ENGINE |
| 3 & 5 | PQNMK30 | 20/30 GALLON MAINTENANCE KIT |
| 6 - 12 | PQ638 | 20/30/55 GALLON LIQUID SHUT-OFF ASSEMBLY |
| 10 - 12 | PQ638F | 20/30/55 GALLON WIRE CAGE COALESCING FILTER |
| 13-14 | PQ635H | HEPA FILTER W/ PRE-FILTER BAG |

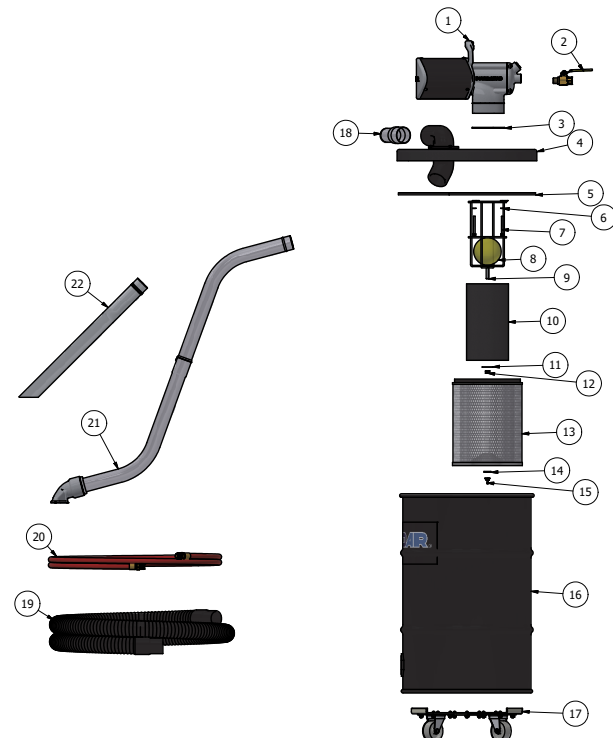

PRODUCT SCHEMATICS

55 GALLON VACUUM KIT WITH 1.5" INLET

| Item No. | Part No. | Description |
|----------|----------|---|
| 1 | PQNVGA | POWERQUAD VACUUM ENGINE (SEE FIGURE 1) |
| 2 | N651 | 1/2 NPT BALL VALVE, BRASS |
| 3 | N682 | GASKET |
| 4 | N900H16* | 55 GALLON DRUM COVER |
| 5 | N656 | DRUM GASKET |
| 6 | N6271* | WASHER |
| 7 | N900H21* | SCREW |
| 8 | N6381* | BALL FLOAT |
| 9 | N900H18* | WIRE CAGE |
| 10 | N900H20* | WIRE CAGE COALESCING FILTER |
| 11 | N900H19* | WASHER |
| 12 | N600H2* | NUT |
| 13 | PQ635 | STANDARD FILTER |
| 14 | - | CONDUCTIVE SEALING WASHER (COMES WITH FILTER) |
| 15 | 2000H10* | WING NUT |
| 16 | N650 | 55-GALLON STANDARD DRUM |
| 17 | N668 | 55-GALLON DRUM DOLLY |
| 18 | N715 | 1-1/2" VACUUM HOSE ADAPTOR |
| 19 | N69110 | 1-1/2" X 10' STANDARD VACUUM HOSE |
| 20 | 12X12GP | 1/2" X 12' STANDARD AIR HOSE |
| 21 | N692 | 1 1/2" FLOOR TOOL |
| 22 | N693 | 24" CREVICE TOOL |

Items (*) are not sellable on their own.

| Replacement Kits & Maintenance | | |
|--------------------------------|----------|---|
| Item No. | Part No. | Description |
| 1, 3, 6, & 7 | PQNVGA | VACUUM GENERATING ENGINE |
| 3 & 5 | PQNMK55 | 55 GALLON MAINTENANCE KIT |
| 6 - 12 | PQ638 | 20/30/55 GALLON LIQUID SHUT-OFF ASSEMBLY |
| 10 - 12 | PQ638F | 20/30/55 GALLON WIRE CAGE COALESCING FILTER |
| 13-14 | PQ635H | HEPA FILTER W/ PRE-FILTER BAG |

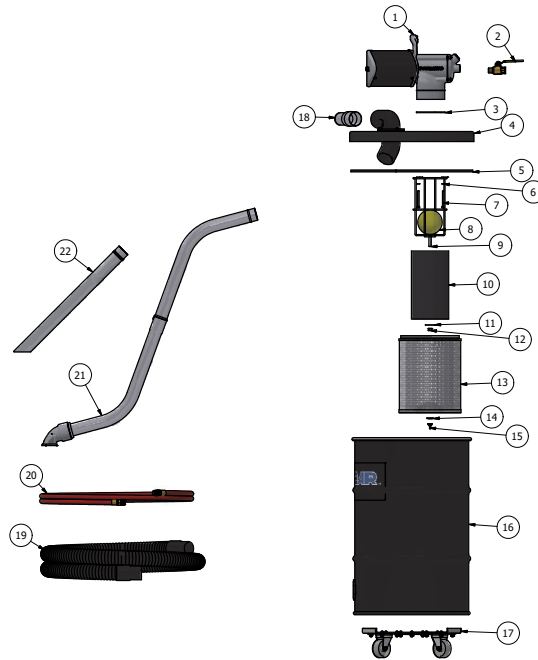

55 GALLON VACUUM KIT WITH 2" INLET

| Item No. | Part No. | Description |
|----------|----------|---|
| 1 | PQNVGA | POWERQUAD VACUUM ENGINE (SEE FIGURE 1) |
| 2 | N651 | 1/2 NPT BALL VALVE, BRASS |
| 3 | N682 | GASKET |
| 4 | N900H16* | 55 GALLON DRUM COVER |
| 5 | N656 | DRUM GASKET |
| 6 | N6271* | WASHER |
| 7 | N900H21* | SCREW |
| 8 | N6381* | BALL FLOAT |
| 9 | N900H18* | WIRE CAGE |
| 10 | N900H20* | WIRE CAGE COALESCING FILTER |
| 11 | N900H19* | WASHER |
| 12 | N600H2* | NUT |
| 13 | PQ635 | STANDARD FILTER |
| 14 | - | CONDUCTIVE SEALING WASHER (COMES WITH FILTER) |
| 15 | 2000H10* | WING NUT |
| 16 | N650 | 55-GALLON STANDARD DRUM |
| 17 | N668 | 55-GALLON DRUM DOLLY |
| 18 | N720 | 2" VACUUM HOSE ADAPTOR |
| 19 | N67010 | 2" X 10' STANDARD VACUUM HOSE |
| 20 | 12X12GP | 1/2" X 12' STANDARD AIR HOSE |
| 21 | N639 | 2" FLOOR TOOL |
| 22 | N693 | 24" CREVICE TOOL |

Items (*) are not sellable on their own.

| Replacement Kits & Maintenance | | |
|--------------------------------|----------|---|
| Item No. | Part No. | Description |
| 1, 3, 6, & 7 | PQNVGA | VACUUM GENERATING ENGINE |
| 3 & 5 | PQNMK55 | 55 GALLON MAINTENANCE KIT |
| 6 - 12 | PQ638 | 20/30/55 GALLON LIQUID SHUT-OFF ASSEMBLY |
| 10 - 12 | PQ638F | 20/30/55 GALLON WIRE CAGE COALESCING FILTER |
| 13-14 | PQ635H | HEPA FILTER W/ PRE-FILTER BAG |

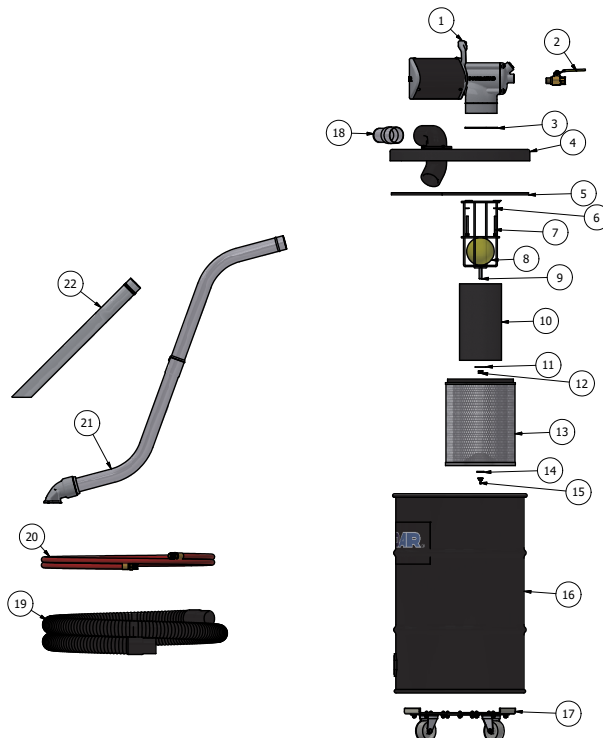

20 GALLON VACUUM KIT WITH 1.5" INLET (NED)

| Item No. | Part No. | Description |
|----------|------------|---|
| 1 | PQNVGA | POWERQUAD VACUUM ENGINE (SEE FIGURE 1) |
| 2 | N651 | 1/2 NPT BALL VALVE, BRASS |
| 3 | N682 | GASKET |
| 4 | N900H15* | 20 & 30 GALLON DRUM COVER |
| 5 | N655 | DRUM GASKET |
| 6 | N6271* | WASHER |
| 7 | N900H21* | SCREW |
| 8 | N6381* | BALL FLOAT |
| 9 | N900H18* | WIRE CAGE |
| 10 | N900H20* | WIRE CAGE COALESCING FILTER |
| 11 | N900H19* | WASHER |
| 12 | N600H2* | NUT |
| 13 | PQ635 | STANDARD FILTER |
| 14 | - | CONDUCTIVE SEALING WASHER (COMES WITH FILTER) |
| 15 | 2000H10* | WING NUT |
| 16 | N200 | 20-GALLON STANDARD DRUM |
| 17 | N667 | 20/30-GALLON DRUM DOLLY |
| 18 | N715 | 1-1/2" VACUUM HOSE ADAPTOR |
| 19 | 2100A02NED | 1-1/2" X 10' STANDARD VACUUM HOSE |
| 20 | 12X12SC | 1/2" X 12' STANDARD AIR HOSE |
| 21 | N692 | 1 1/2" FLOOR TOOL |
| 22 | N693 | 24" CREVICE TOOL |

Items (*) are not sellable on their own.

| Replacement Kits & Maintenance | | |
|--------------------------------|----------|---|
| Item No. | Part No. | Description |
| 1, 3, 6, & 7 | PQNVGA | VACUUM GENERATING ENGINE |
| 3 & 5 | PQNMK30 | 20/30 GALLON MAINTENANCE KIT |
| 6 - 12 | PQ638 | 20/30/55 GALLON LIQUID SHUT-OFF ASSEMBLY |
| 10 - 12 | PQ638F | 20/30/55 GALLON WIRE CAGE COALESCING FILTER |
| 13-14 | PQ635H | HEPA FILTER W/ PRE-FILTER BAG |

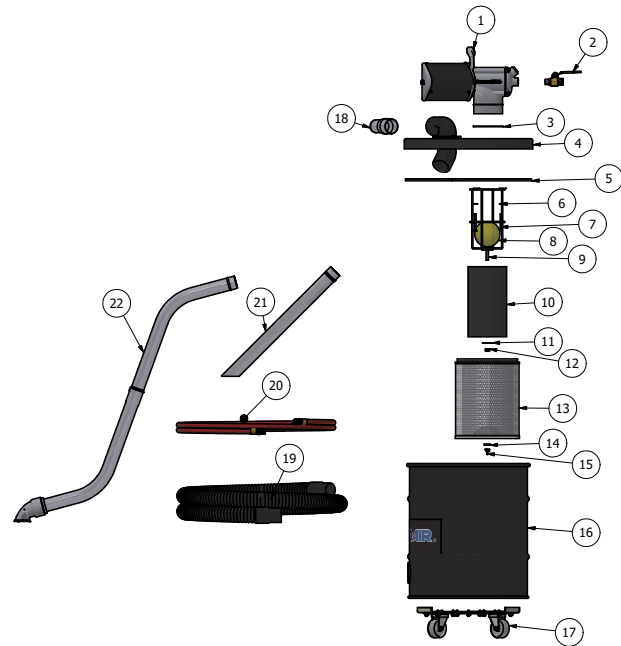

20 GALLON VACUUM KIT WITH 2" INLET (NED)

| Item No. | Part No. | Description |
|----------|----------|---|
| 1 | PQNVGA | POWERQUAD VACUUM ENGINE (SEE FIGURE 1) |
| 2 | N651 | 1/2 NPT BALL VALVE, BRASS |
| 3 | N682 | GASKET |
| 4 | N900H15* | 20 & 30 GALLON DRUM COVER |
| 5 | N655 | DRUM GASKET |
| 6 | N6271* | WASHER |
| 7 | N900H21* | SCREW |
| 8 | N6381* | BALL FLOAT |
| 9 | N900H18* | WIRE CAGE |
| 10 | N900H20* | WIRE CAGE COALESCING FILTER |
| 11 | N900H19* | WASHER |
| 12 | N600H2* | NUT |
| 13 | PQ635 | STANDARD FILTER |
| 14 | - | CONDUCTIVE SEALING WASHER (COMES WITH FILTER) |
| 15 | 2000H10* | WING NUT |
| 16 | N200 | 20-GALLON STANDARD DRUM |
| 17 | N667 | 20/30-GALLON DRUM DOLLY |
| 18 | N720 | 2" VACUUM HOSE ADAPTOR |
| 19 | N652 | 2" X 10' STANDARD VACUUM HOSE |
| 20 | 12X12SC | 1/2" X 12' STANDARD AIR HOSE |
| 21 | N639 | 2" FLOOR TOOL |
| 22 | N693 | 24" CREVICE TOOL |

Items (*) are not sellable on their own.

| Replacement Kits & Maintenance | | |
|--------------------------------|----------|---|
| Item No. | Part No. | Description |
| 1, 3, 6, & 7 | PQNVGA | VACUUM GENERATING ENGINE |
| 3 & 5 | PQNMK30 | 20/30 GALLON MAINTENANCE KIT |
| 6 - 12 | PQ638 | 20/30/55 GALLON LIQUID SHUT-OFF ASSEMBLY |
| 10 - 12 | PQ638F | 20/30/55 GALLON WIRE CAGE COALESCING FILTER |
| 13-14 | PQ635H | HEPA FILTER W/ PRE-FILTER BAG |

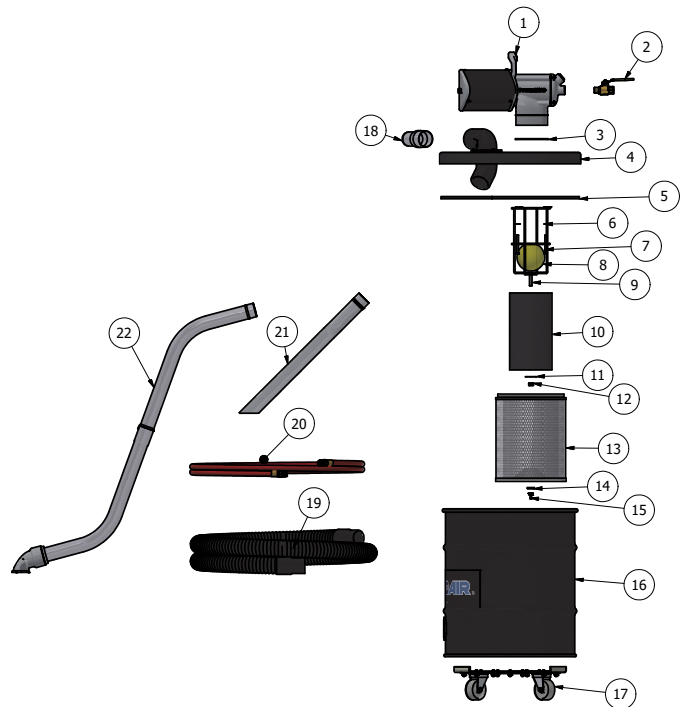

PRODUCT SCHEMATICS

30 GALLON VACUUM KIT WITH 1.5" INLET (NED)

| Item No. | Part No. | Description |
|----------|------------|---|
| 1 | PQNVGA | POWERQUAD VACUUM ENGINE (SEE FIGURE 1) |
| 2 | N651 | 1/2 NPT BALL VALVE, BRASS |
| 3 | N682 | GASKET |
| 4 | N900H15* | 20 & 30 GALLON DRUM COVER |
| 5 | N655 | DRUM GASKET |
| 6 | N6271* | WASHER |
| 7 | N900H21* | SCREW |
| 8 | N6381* | BALL FLOAT |
| 9 | N900H18* | WIRE CAGE |
| 10 | N900H20* | WIRE CAGE COALESCING FILTER |
| 11 | N900H19* | WASHER |
| 12 | N600H2* | NUT |
| 13 | PQ635 | STANDARD FILTER |
| 14 | - | CONDUCTIVE SEALING WASHER (COMES WITH FILTER) |
| 15 | 2000H10* | WING NUT |
| 16 | N630 | 30-GALLON STANDARD DRUM |
| 17 | N667 | 20/30-GALLON DRUM DOLLY |
| 18 | N715 | 1-1/2" VACUUM HOSE ADAPTOR |
| 19 | Z100A02NED | 1-1/2" X 10' STANDARD VACUUM HOSE |
| 20 | 12X125C | 1/2" X 12' STANDARD AIR HOSE |
| 21 | N692 | 1 1/2" FLOOR TOOL |
| 22 | N693 | 24" CREVICE TOOL |

Items (*) are not sellable on their own.

| Replacement Kits & Maintenance | | |
|--------------------------------|----------|---|
| Item No. | Part No. | Description |
| 1, 3, 6, & 7 | PQNVGA | VACUUM GENERATING ENGINE |
| 3 & 5 | PQNMK30 | 20/30 GALLON MAINTENANCE KIT |
| 6 - 12 | PQ638 | 20/30/55 GALLON LIQUID SHUT-OFF ASSEMBLY |
| 10 - 12 | PQ638F | 20/30/55 GALLON WIRE CAGE COALESCING FILTER |
| 13-14 | PQ635H | HEPA FILTER W/ PRE-FILTER BAG |

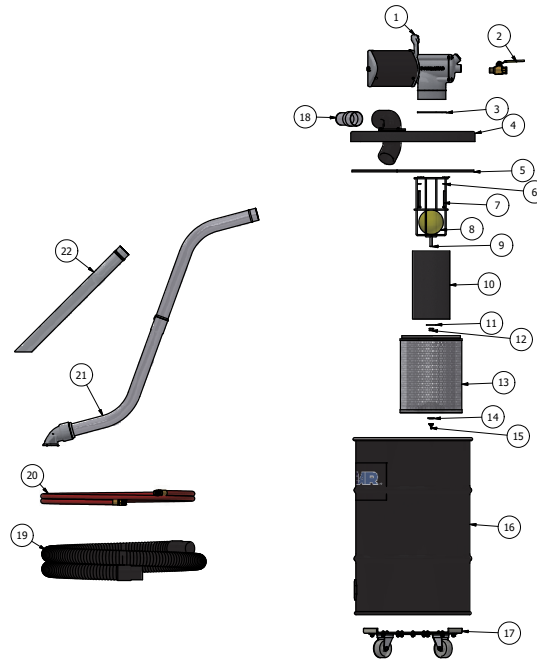

30 GALLON VACUUM KIT WITH 2" INLET (NED)

| Item No. | Part No. | Description |
|----------|----------|---|
| 1 | PQNVGA | POWERQUAD VACUUM ENGINE (SEE FIGURE 1) |
| 2 | N651 | 1/2 NPT BALL VALVE, BRASS |
| 3 | N682 | GASKET |
| 4 | N900H15* | 20 & 30 GALLON DRUM COVER |
| 5 | N655 | DRUM GASKET |
| 6 | N6271* | WASHER |
| 7 | N900H21* | SCREW |
| 8 | N6381* | BALL FLOAT |
| 9 | N900H18* | WIRE CAGE |
| 10 | N900H20* | WIRE CAGE COALESCING FILTER |
| 11 | N900H19* | WASHER |
| 12 | N600H2* | NUT |
| 13 | PQ635 | STANDARD FILTER |
| 14 | - | CONDUCTIVE SEALING WASHER (COMES WITH FILTER) |
| 15 | 2000H10* | WING NUT |
| 16 | N630 | 30-GALLON STANDARD DRUM |
| 17 | N667 | 20/30-GALLON DRUM DOLLY |
| 18 | N720 | 2" VACUUM HOSE ADAPTOR |
| 19 | N652 | 2" X 10' STANDARD VACUUM HOSE |
| 20 | 12X125C | 1/2" X 12' STANDARD AIR HOSE |
| 21 | N639 | 2" FLOOR TOOL |
| 22 | N693 | 24" CREVICE TOOL |

Items (*) are not sellable on their own.

| Replacement Kits & Maintenance | | |
|--------------------------------|----------|---|
| Item No. | Part No. | Description |
| 1, 3, 6, & 7 | PQNVGA | VACUUM GENERATING ENGINE |
| 3 & 5 | PQNMK30 | 20/30 GALLON MAINTENANCE KIT |
| 6 - 12 | PQ638 | 20/30/55 GALLON LIQUID SHUT-OFF ASSEMBLY |
| 10 - 12 | PQ638F | 20/30/55 GALLON WIRE CAGE COALESCING FILTER |
| 13-14 | PQ635H | HEPA FILTER W/ PRE-FILTER BAG |

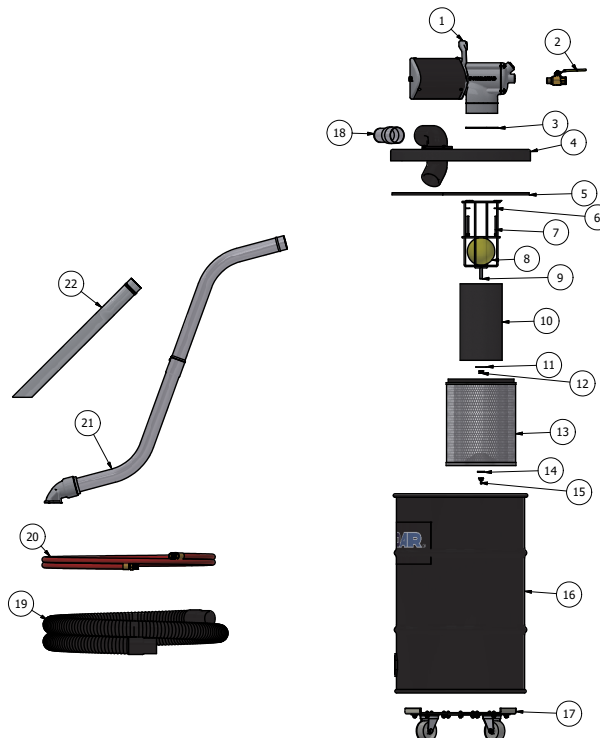

55 GALLON VACUUM KIT WITH 1.5" INLET (NED)

| Item No. | Part No. | Description |
|----------|-----------|---|
| 1 | PQNVGA | POWERQUAD VACUUM ENGINE (SEE FIGURE 1) |
| 2 | N651 | 1/2 NPT BALL VALVE, BRASS |
| 3 | N682 | GASKET |
| 4 | N900H16* | 55 GALLON DRUM COVER |
| 5 | N656 | DRUM GASKET |
| 6 | N6271* | WASHER |
| 7 | N900H21* | SCREW |
| 8 | N6381* | BALL FLOAT |
| 9 | N900H18* | WIRE CAGE |
| 10 | N900H20* | WIRE CAGE COALESCING FILTER |
| 11 | N900H19* | WASHER |
| 12 | N600H2* | NUT |
| 13 | PQ635 | STANDARD FILTER |
| 14 | - | CONDUCTIVE SEALING WASHER (COMES WITH FILTER) |
| 15 | 2000H10* | WING NUT |
| 16 | N650 | 55-GALLON STANDARD DRUM |
| 17 | N668 | 55-GALLON DRUM DOLLY |
| 18 | N715 | 1-1/2" VACUUM HOSE ADAPTOR |
| 19 | 210A02NED | 1-1/2" X 10' STANDARD VACUUM HOSE |
| 20 | 12X12SC | 1/2" X 12' STANDARD AIR HOSE |
| 21 | N692 | 1 1/2" FLOOR TOOL |
| 22 | N693 | 24" CREVICE TOOL |

Items (*) are not sellable on their own.

| Replacement Kits & Maintenance | | |
|--------------------------------|----------|---|
| Item No. | Part No. | Description |
| 1, 3, 6, & 7 | PQNVGA | VACUUM GENERATING ENGINE |
| 3 & 5 | PQNMK55 | 55 GALLON MAINTENANCE KIT |
| 6 - 12 | PQ638 | 20/30/55 GALLON LIQUID SHUT-OFF ASSEMBLY |
| 10 - 12 | PQ638F | 20/30/55 GALLON WIRE CAGE COALESCING FILTER |
| 13-14 | PQ635H | HEPA FILTER W/ PRE-FILTER BAG |

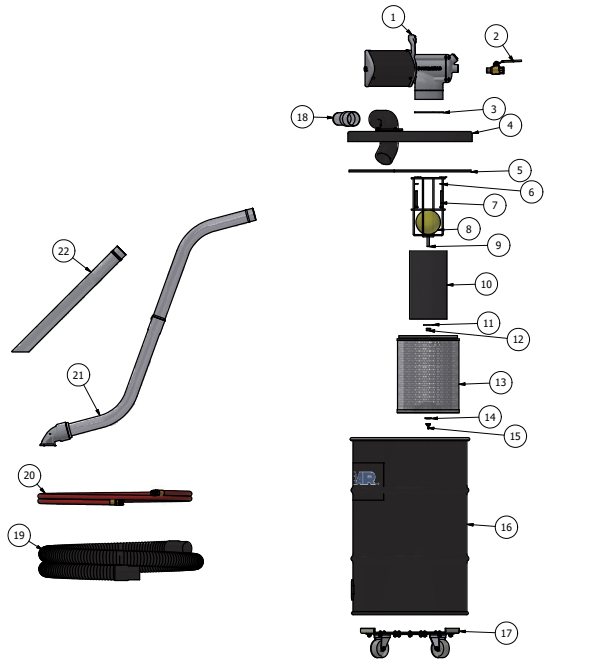

55 GALLON VACUUM KIT WITH 2" INLET (NED)

| Item No. | Part No. | Description |
|----------|----------|---|
| 1 | PQNVGA | POWERQUAD VACUUM ENGINE (SEE FIGURE 1) |
| 2 | N651 | 1/2 NPT BALL VALVE, BRASS |
| 3 | N682 | GASKET |
| 4 | N900H16* | 55 GALLON DRUM COVER |
| 5 | N656 | DRUM GASKET |
| 6 | N6271* | WASHER |
| 7 | N900H21* | SCREW |
| 8 | N6381* | BALL FLOAT |
| 9 | N900H18* | WIRE CAGE |
| 10 | N900H20* | WIRE CAGE COALESCING FILTER |
| 11 | N900H19* | WASHER |
| 12 | N600H2* | NUT |
| 13 | PQ635 | STANDARD FILTER |
| 14 | - | CONDUCTIVE SEALING WASHER (COMES WITH FILTER) |
| 15 | 2000H10* | WING NUT |
| 16 | N650 | 55-GALLON STANDARD DRUM |
| 17 | N668 | 55-GALLON DRUM DOLLY |
| 18 | N720 | 2" VACUUM HOSE ADAPTOR |
| 19 | N652 | 2" X 10' STANDARD VACUUM HOSE |
| 20 | 12X12SC | 1/2" X 12' STANDARD AIR HOSE |
| 21 | N639 | 2" FLOOR TOOL |
| 22 | N693 | 24" CREVICE TOOL |

Items (*) are not sellable on their own.

| Replacement Kits & Maintenance | | |
|--------------------------------|----------|---|
| Item No. | Part No. | Description |
| 1, 3, 6, & 7 | PQNVGA | VACUUM GENERATING ENGINE |
| 3 & 5 | PQNMK55 | 55 GALLON MAINTENANCE KIT |
| 6 - 12 | PQ638 | 20/30/55 GALLON LIQUID SHUT-OFF ASSEMBLY |
| 10 - 12 | PQ638F | 20/30/55 GALLON WIRE CAGE COALESCING FILTER |
| 13-14 | PQ635H | HEPA FILTER W/ PRE-FILTER BAG |

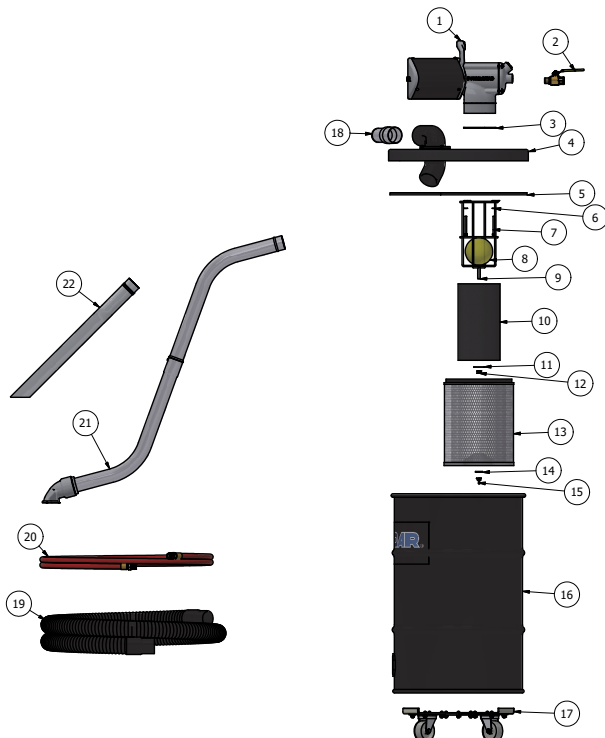

PRODUCT SCHEMATICS

20 GALLON VACUUM KIT WITH 1.5" INLET (PULSEAIR)

| Item No. | Part No. | Description |
|----------|------------|---|
| 1 | PQNVGA | POWERQUAD VACUUM ENGINE (SEE FIGURE 1) |
| 2 | N651 | 1/2 NPT BALL VALVE, BRASS |
| 3 | N7361* | CLOSE NIPPLE |
| 4 | N7362* | REDUCING TEE |
| 5 | N7315* | PUSH TO CONNECT FITTING |
| 6 | N7316* | TUBING |
| 7 | N682 | GASKET |
| 8 | N900A30M* | 20 & 30 GALLON COVER ASSEMBLY |
| 9 | N655 | DRUM GASKET |
| 10 | N6271* | 1/4 INTERNAL TOOTH LOCK WASHER |
| 11 | N900H22* | SCREW |
| 12 | N900H18* | WIRE CAGE |
| 13 | PQ635H | HEPA FILTER |
| 14 | - | CONDUCTIVE SEALING WASHER (COMES WITH FILTER) |
| 15 | 2000H10* | WING NUT |
| 16 | N730X03M* | PULSEAIR MANIFOLD |
| 17 | N715 | 1-1/2" VACUUM HOSE ADAPTOR |
| 18 | AV2005* | LID CLAMP |
| 19 | N737* | PRE-FILTER BAG CLAMP |
| 20 | N635B | PRE-FILTER BAG |
| 21 | N200 | 20 GALLON STANDARD PULSEAIR DRUM |
| 22 | N667 | 20 & 30-GALLON DRUM DOLLY |
| 23 | 2100A02NED | 1-1/2" X 10' STATIC CONDUCTIVE VACUUM HOSE |
| 24 | 12X12SC | 1/2" X 12' STATIC CONDUCTIVE AIR HOSE |
| 25 | N692 | 1 1/2" FLOOR TOOL |
| 26 | N693 | 1-1/2" CREVICE TOOL |

Items (*) are not sellable on their own.

| Replacement Kits & Maintenance | | |
|--------------------------------|----------|--|
| Item No. | Part No. | Description |
| 1, 7, 10, & 11 | PQNVGA | VACUUM GENERATING ENGINE |
| 7 & 9 | PQNMK30 | 20/30 GALLON MAINTENANCE KIT |
| 10-14 | PQ638 | 20/30/55 GALLON LIQUID SHUT-OFF ASSEMBLY |
| 13, 14, & 20 | PQ635H | HEPA FILTER W/ PRE-FILTER BAG |

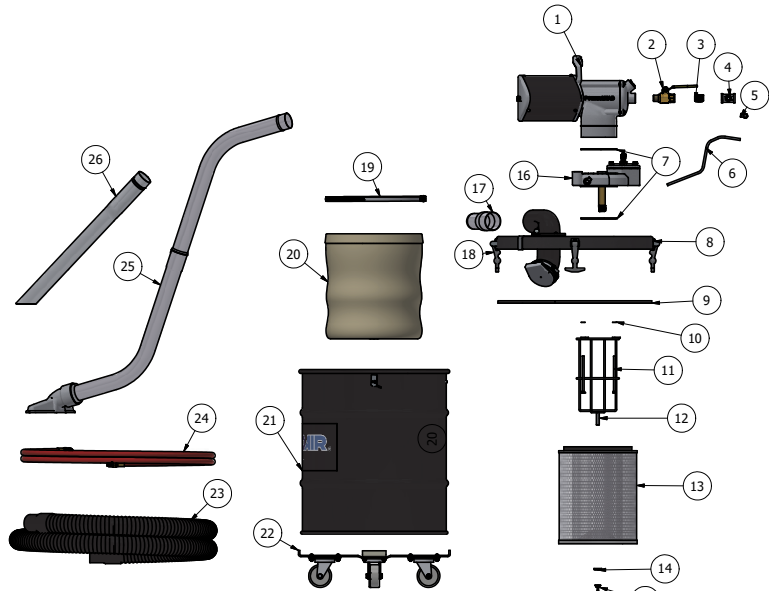

20 GALLON VACUUM KIT WITH 2" INLET (PULSEAIR)

| Item No. | Part No. | Description |
|----------|-----------|---|
| 1 | PQNVGA | POWERQUAD VACUUM ENGINE (SEE FIGURE 1) |
| 2 | N651 | 1/2 NPT BALL VALVE, BRASS |
| 3 | N7361* | CLOSE NIPPLE |
| 4 | N7362* | REDUCING TEE |
| 5 | N7315* | PUSH TO CONNECT FITTING |
| 6 | N7316* | TUBING |
| 7 | N682 | GASKET |
| 8 | N900A30M* | 20 & 30 GALLON COVER ASSEMBLY |
| 9 | N655 | DRUM GASKET |
| 10 | N6271* | 1/4 INTERNAL TOOTH LOCK WASHER |
| 11 | N900H22* | SCREW |
| 12 | N900H18* | WIRE CAGE |
| 13 | PQ635H | HEPA FILTER |
| 14 | - | CONDUCTIVE SEALING WASHER (COMES WITH FILTER) |
| 15 | 2000H10* | WING NUT |
| 16 | N730X03M* | PULSEAIR MANIFOLD |
| 17 | N715 | 1-1/2" VACUUM HOSE ADAPTOR |
| 18 | AV2005* | LID CLAMP |
| 19 | N737* | PRE-FILTER BAG CLAMP |
| 20 | N635B | PRE-FILTER BAG |
| 21 | N200 | 20 GALLON STANDARD PULSEAIR DRUM |
| 22 | N667 | 20 & 30-GALLON DRUM DOLLY |
| 23 | N652 | 2" X 10' STATIC CONDUCTIVE VACUUM HOSE |
| 24 | 12X12SC | 1/2" X 12' STATIC CONDUCTIVE AIR HOSE |
| 25 | N639 | 2" FLOOR TOOL |
| 26 | N693 | 2" CREVICE TOOL |

Items (*) are not sellable on their own.

| Replacement Kits & Maintenance | | |
|--------------------------------|----------|--|
| Item No. | Part No. | Description |
| 1, 7, 10, & 11 | PQNVGA | VACUUM GENERATING ENGINE |
| 7 & 9 | PQNMK30 | 20/30 GALLON MAINTENANCE KIT |
| 10-14 | PQ638 | 20/30/55 GALLON LIQUID SHUT-OFF ASSEMBLY |
| 13, 14, & 20 | PQ635H | HEPA FILTER W/ PRE-FILTER BAG |

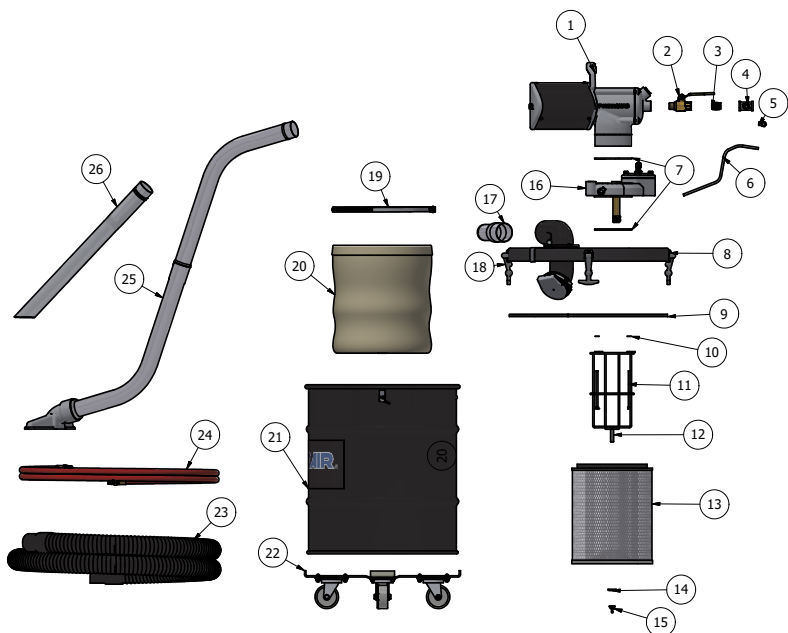

30 GALLON VACUUM KIT WITH 1.5" INLET (PULSEAIR)

| Item No. | Part No. | Description |
|----------|------------|---|
| 1 | PQNVGA | POWERQUAD VACUUM ENGINE (SEE FIGURE 1) |
| 2 | N651 | 1/2 NPT BALL VALVE, BRASS |
| 3 | N7361* | CLOSE NIPPLE |
| 4 | N7362* | REDUCING TEE |
| 5 | N7315* | PUSH TO CONNECT FITTING |
| 6 | N7316* | TUBING |
| 7 | N682 | GASKET |
| 8 | N900A30M* | 20 & 30 GALLON COVER ASSEMBLY |
| 9 | N655 | DRUM GASKET |
| 10 | N6271* | 1/4 INTERNAL TOOTH LOCK WASHER |
| 11 | N900H22* | SCREW |
| 12 | N900H18* | WIRE CAGE |
| 13 | PQ635H | HEPA FILTER |
| 14 | - | CONDUCTIVE SEALING WASHER (COMES WITH FILTER) |
| 15 | 2000H10* | WING NUT |
| 16 | N730X03M* | PULSEAIR MANIFOLD |
| 17 | N715 | 1-1/2" VACUUM HOSE ADAPTOR |
| 18 | AV2005* | LID CLAMP |
| 19 | N737* | PRE-FILTER BAG CLAMP |
| 20 | N635B | PRE-FILTER BAG |
| 21 | N630 | 30 GALLON STANDARD PULSEAIR DRUM |
| 22 | N667 | 20 & 30-GALLON DRUM DOLLY |
| 23 | 2100A02NED | 1-1/2" X 10' STATIC CONDUCTIVE VACUUM HOSE |
| 24 | 12X12SC | 1/2" X 12' STATIC CONDUCTIVE AIR HOSE |
| 25 | N692 | 1 1/2" FLOOR TOOL |
| 26 | N693 | 1-1/2" CREVICE TOOL |

Items (*) are not sellable on their own.

| Replacement Kits & Maintenance | | |
|--------------------------------|----------|--|
| Item No. | Part No. | Description |
| 1, 7, 10, & 11 | PQNVGA | VACUUM GENERATING ENGINE |
| 7 & 9 | PQNMK30 | 20/30 GALLON MAINTENANCE KIT |
| 10-14 | PQ638 | 20/30/55 GALLON LIQUID SHUT-OFF ASSEMBLY |
| 13, 14, & 20 | PQ635H | HEPA FILTER W/ PRE-FILTER BAG |

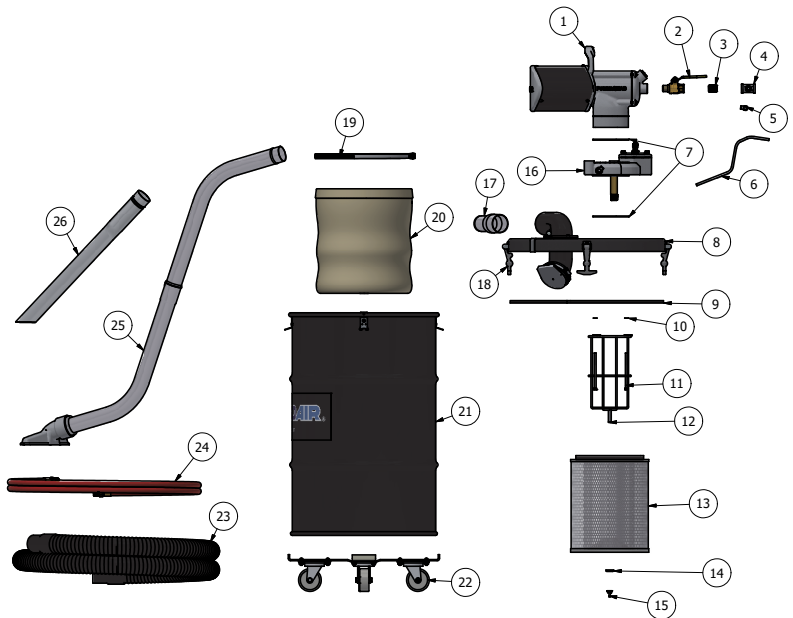

30 GALLON VACUUM KIT WITH 2" INLET (PULSEAIR)

| Item No. | Part No. | Description |
|----------|-----------|---|
| 1 | PQNVGA | POWERQUAD VACUUM ENGINE (SEE FIGURE 1) |
| 2 | N651 | 1/2 NPT BALL VALVE, BRASS |
| 3 | N7361* | CLOSE NIPPLE |
| 4 | N7362* | REDUCING TEE |
| 5 | N7315* | PUSH TO CONNECT FITTING |
| 6 | N7316* | TUBING |
| 7 | N682 | GASKET |
| 8 | N900A30M* | 20 & 30 GALLON COVER ASSEMBLY |
| 9 | N655 | DRUM GASKET |
| 10 | N6271* | 1/4 INTERNAL TOOTH LOCK WASHER |
| 11 | N900H22* | SCREW |
| 12 | N900H18* | WIRE CAGE |
| 13 | PQ635H | HEPA FILTER |
| 14 | - | CONDUCTIVE SEALING WASHER (COMES WITH FILTER) |
| 15 | 2000H10* | WING NUT |
| 16 | N730X03M* | PULSEAIR MANIFOLD |
| 17 | N715 | 1-1/2" VACUUM HOSE ADAPTOR |
| 18 | AV2005* | LID CLAMP |
| 19 | N737* | PRE-FILTER BAG CLAMP |
| 20 | N635B | PRE-FILTER BAG |
| 21 | N630 | 30 GALLON STANDARD PULSEAIR DRUM |
| 22 | N667 | 20 & 30-GALLON DRUM DOLLY |
| 23 | N652 | 2" X 10' STATIC CONDUCTIVE VACUUM HOSE |
| 24 | 12X12SC | 1/2" X 12' STATIC CONDUCTIVE AIR HOSE |
| 25 | N639 | 2" FLOOR TOOL |
| 26 | N693 | 2" CREVICE TOOL |

Items (*) are not sellable on their own.

| Replacement Kits & Maintenance | | |
|--------------------------------|----------|--|
| Item No. | Part No. | Description |
| 1, 7, 10, & 11 | PQNVGA | VACUUM GENERATING ENGINE |
| 7 & 9 | PQNMK30 | 20/30 GALLON MAINTENANCE KIT |
| 10-14 | PQ638 | 20/30/55 GALLON LIQUID SHUT-OFF ASSEMBLY |
| 13, 14, & 20 | PQ635H | HEPA FILTER W/ PRE-FILTER BAG |

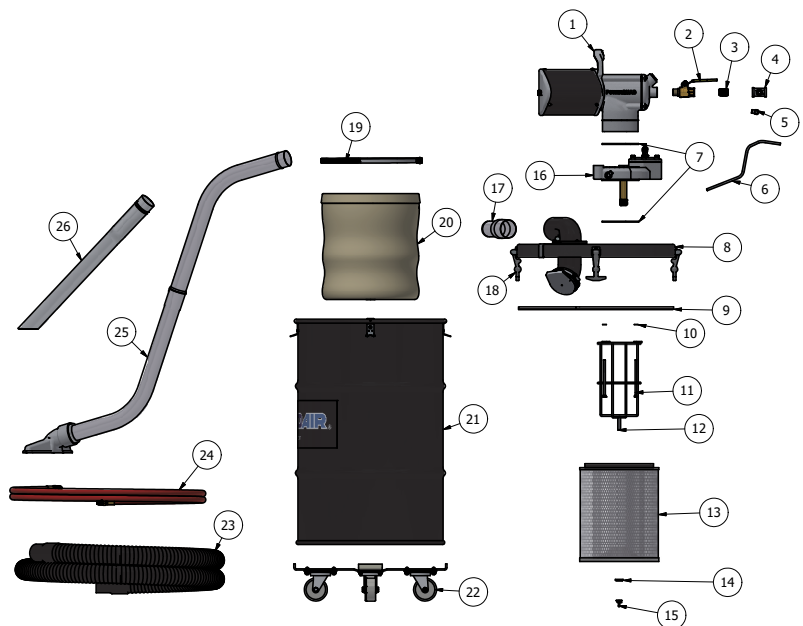

PRODUCT SCHEMATICS

55 GALLON VACUUM KIT WITH 1.5" INLET (PULSEAIR)

| Item No. | Part No. | Description |
|----------|------------|---|
| 1 | PQNVGA | POWERQUAD VACUUM ENGINE (SEE FIGURE 1) |
| 2 | N651 | 1/2 NPT BALL VALVE, BRASS |
| 3 | N7361* | CLOSE NIPPLE |
| 4 | N7362* | REDUCING TEE |
| 5 | N7315* | PUSH TO CONNECT FITTING |
| 6 | N7316* | TUBING |
| 7 | N682 | GASKET |
| 8 | N900A37M* | 55 GALLON COVER ASSEMBLY |
| 9 | N656 | DRUM GASKET |
| 10 | N6271* | 1/4 INTERNAL TOOTH LOCK WASHER |
| 11 | N900H22* | SCREW |
| 12 | N900H18* | WIRE CAGE |
| 13 | PQ635H | HEPA FILTER |
| 14 | - | CONDUCTIVE SEALING WASHER (COMES WITH FILTER) |
| 15 | 2000H10* | WING NUT |
| 16 | N730X03M* | PULSEAIR MANIFOLD |
| 17 | N715 | 1-1/2" VACUUM HOSE ADAPTOR |
| 18 | AV2005* | LID CLAMP |
| 19 | N737* | PRE-FILTER BAG CLAMP |
| 20 | N635B | PRE-FILTER BAG |
| 21 | N650 | 55 GALLON STANDARD PULSEAIR DRUM |
| 22 | N668 | 55-GALLON DRUM DOLLY |
| 23 | 2100A02NED | 1-1/2" X 10' STATIC CONDUCTIVE VACUUM HOSE |
| 24 | 12X12SC | 1/2" X 12' STATIC CONDUCTIVE AIR HOSE |
| 25 | N692 | 1 1/2" FLOOR TOOL |
| 26 | N693 | 1-1/2" CREVICE TOOL |

Items (*) are not sellable on their own.

| Replacement Kits & Maintenance | | |
|--------------------------------|----------|--|
| Item No. | Part No. | Description |
| 1, 7, 10, & 11 | PQNVGA | VACUUM GENERATING ENGINE |
| 7 & 9 | PQNMK55 | 55 GALLON MAINTENANCE KIT |
| 10-14 | PQ638 | 20/30/55 GALLON LIQUID SHUT-OFF ASSEMBLY |
| 13, 14, & 20 | PQ635H | HEPA FILTER W/ PRE-FILTER BAG |

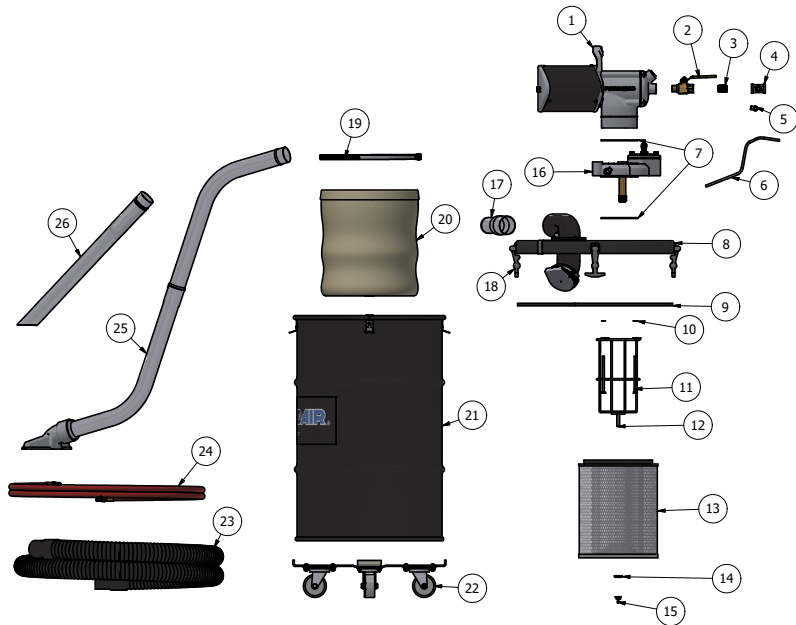

55 GALLON VACUUM KIT WITH 2" INLET (PULSEAIR)

| Item No. | Part No. | Description |
|----------|-----------|---|
| 1 | PQNVGA | POWERQUAD VACUUM ENGINE (SEE FIGURE 1) |
| 2 | N651 | 1/2 NPT BALL VALVE, BRASS |
| 3 | N7361* | CLOSE NIPPLE |
| 4 | N7362* | REDUCING TEE |
| 5 | N7315* | PUSH TO CONNECT FITTING |
| 6 | N7316* | TUBING |
| 7 | N682 | GASKET |
| 8 | N900A37M* | 55 GALLON COVER ASSEMBLY |
| 9 | N656 | DRUM GASKET |
| 10 | N6271* | 1/4 INTERNAL TOOTH LOCK WASHER |
| 11 | N900H22* | SCREW |
| 12 | N900H18* | WIRE CAGE |
| 13 | PQ635H | HEPA FILTER |
| 14 | - | CONDUCTIVE SEALING WASHER (COMES WITH FILTER) |
| 15 | 2000H10* | WING NUT |
| 16 | N730X03M* | PULSEAIR MANIFOLD |
| 17 | N715 | 1-1/2" VACUUM HOSE ADAPTOR |
| 18 | AV2005* | LID CLAMP |
| 19 | N737* | PRE-FILTER BAG CLAMP |
| 20 | N635B | PRE-FILTER BAG |
| 21 | N650 | 55 GALLON STANDARD PULSEAIR DRUM |
| 22 | N668 | 55-GALLON DRUM DOLLY |
| 23 | N652 | 2" X 10' STATIC CONDUCTIVE VACUUM HOSE |
| 24 | 12X12SC | 1/2" X 12' STATIC CONDUCTIVE AIR HOSE |
| 25 | N639 | 2" FLOOR TOOL |
| 26 | N693 | 2" CREVICE TOOL |

Items (*) are not sellable on their own.

| Replacement Kits & Maintenance | | |
|--------------------------------|----------|--|
| Item No. | Part No. | Description |
| 1, 7, 10, & 11 | PQNVGA | VACUUM GENERATING ENGINE |
| 7 & 9 | PQNMK55 | 55 GALLON MAINTENANCE KIT |
| 10-14 | PQ638 | 20/30/55 GALLON LIQUID SHUT-OFF ASSEMBLY |
| 13, 14, & 20 | PQ635H | HEPA FILTER W/ PRE-FILTER BAG |

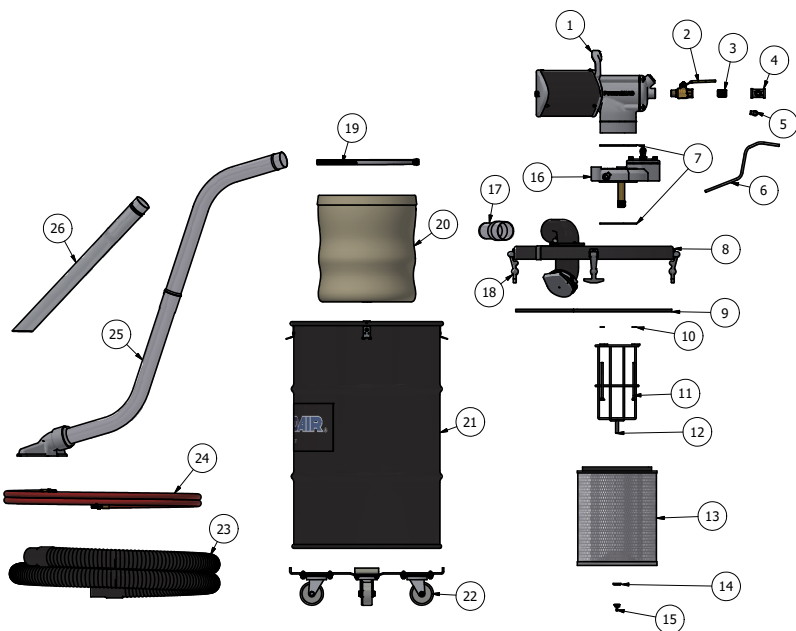

20 GALLON VACUUM KIT WITH 1.5" INLET (DUST EXTRACTOR)

| Item No. | Part No. | Description |
|----------|------------|---|
| 1 | PQNVGA | POWERQUAD VACUUM ENGINE (SEE FIGURE 1) |
| 2 | N651 | 1/2 NPT BALL VALVE, BRASS |
| 3 | N7361* | CLOSE NIPPLE |
| 4 | N7362* | REDUCING TEE |
| 5 | N7315* | PUSH TO CONNECT FITTING |
| 6 | N7316* | TUBING |
| 7 | N682 | GASKET |
| 8 | N900A30M* | 20 & 30 GALLON COVER ASSEMBLY |
| 9 | N655 | DRUM GASKET |
| 10 | N6271* | 1/4 INTERNAL TOOTH LOCK WASHER |
| 11 | N900H22* | SCREW |
| 12 | N900H18 | WIRE CAGE |
| 13 | PQ635H | HEPA FILTER |
| 14 | - | CONDUCTIVE SEALING WASHER (COMES WITH FILTER) |
| 15 | 2000H10* | WING NUT |
| 16 | N730X03M* | PULSEAIR MANIFOLD |
| 17 | N715 | 1-1/2" VACUUM HOSE ADAPTOR |
| 18 | AV2005* | LID CLAMP |
| 19 | N737* | PRE-FILTER BAG CLAMP |
| 20 | N635B | PRE-FILTER BAG |
| 21 | N200 | 20 GALLON STANDARD PULSEAIR DRUM |
| 22 | N667 | 20 & 30-GALLON DRUM DOLLY |
| 23 | 2100A02NED | 1-1/2" X 10' STATIC CONDUCTIVE VACUUM HOSE |
| 24 | 12X125C | 1/2" X 12' STATIC CONDUCTIVE AIR HOSE |

Items (*) are not sellable on their own.

| Replacement Kits & Maintenance | | |
|--------------------------------|----------|--|
| Item No. | Part No. | Description |
| 1, 7, 10, & 11 | PQNVGA | VACUUM GENERATING ENGINE |
| 7 & 9 | PQNMK30 | 20/30 GALLON MAINTENANCE KIT |
| 10-14 | PQ638 | 20/30/55 GALLON LIQUID SHUT-OFF ASSEMBLY |
| 13, 14, & 20 | PQ635H | HEPA FILTER W/ PRE-FILTER BAG |

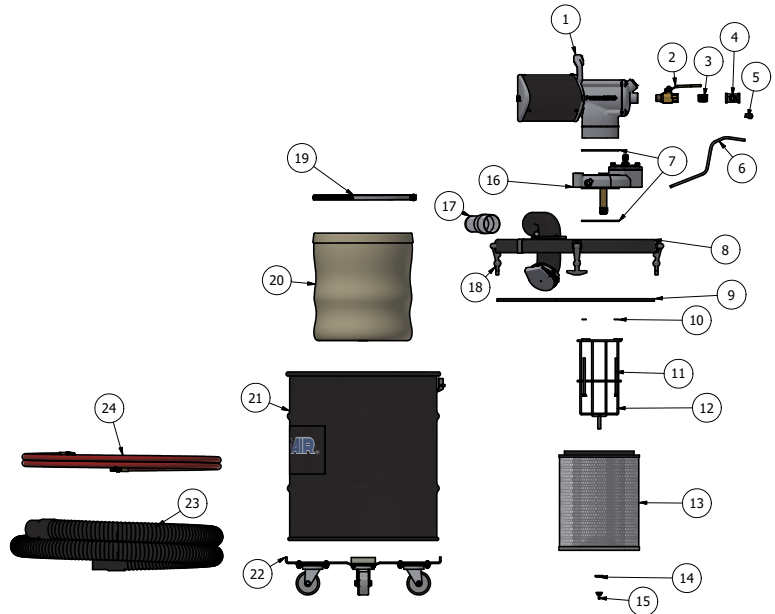

20 GALLON VACUUM KIT WITH 2" INLET (DUST EXTRACTOR)

| Item No. | Part No. | Description |
|----------|-----------|---|
| 1 | PQNVGA | POWERQUAD VACUUM ENGINE (SEE FIGURE 1) |
| 2 | N651 | 1/2 NPT BALL VALVE, BRASS |
| 3 | N7361* | CLOSE NIPPLE |
| 4 | N7362* | REDUCING TEE |
| 5 | N7315* | PUSH TO CONNECT FITTING |
| 6 | N7316* | TUBING |
| 7 | N682 | GASKET |
| 8 | N900A30M* | 20 & 30 GALLON COVER ASSEMBLY |
| 9 | N655 | DRUM GASKET |
| 10 | N6271* | 1/4 INTERNAL TOOTH LOCK WASHER |
| 11 | N900H22* | SCREW |
| 12 | N900H18* | WIRE CAGE |
| 13 | PQ635H | HEPA FILTER |
| 14 | - | CONDUCTIVE SEALING WASHER (COMES WITH FILTER) |
| 15 | 2000H10* | WING NUT |
| 16 | N730X03M* | PULSEAIR MANIFOLD |
| 17 | N715 | 1-1/2" VACUUM HOSE ADAPTOR |
| 18 | AV2005* | LID CLAMP |
| 19 | N737* | PRE-FILTER BAG CLAMP |
| 20 | N635B | PRE-FILTER BAG |
| 21 | N200 | 20 GALLON STANDARD PULSEAIR DRUM |
| 22 | N667 | 20 & 30-GALLON DRUM DOLLY |
| 23 | N652 | 2" X 10' STATIC CONDUCTIVE VACUUM HOSE |
| 24 | 12X125C | 1/2" X 12' STATIC CONDUCTIVE AIR HOSE |

Items (*) are not sellable on their own.

| Replacement Kits & Maintenance | | |
|--------------------------------|----------|--|
| Item No. | Part No. | Description |
| 1, 7, 10, & 11 | PQNVGA | VACUUM GENERATING ENGINE |
| 7 & 9 | PQNMK30 | 20/30 GALLON MAINTENANCE KIT |
| 10-14 | PQ638 | 20/30/55 GALLON LIQUID SHUT-OFF ASSEMBLY |
| 13, 14, & 20 | PQ635H | HEPA FILTER W/ PRE-FILTER BAG |

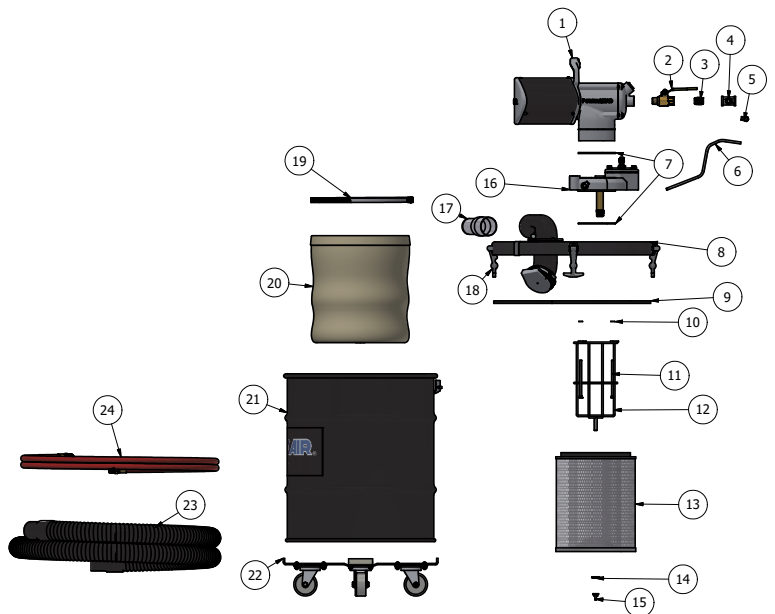

PRODUCT SCHEMATICS

30 GALLON VACUUM KIT WITH/ 1.5" INLET (DUST EXTRACTOR)

| Item No. | Part No. | Description |
|----------|-----------|---|
| 1 | PQNVGA | POWERQUAD VACUUM ENGINE (SEE FIGURE 1) |
| 2 | N651 | 1/2 NPT BALL VALVE, BRASS |
| 3 | N682 | GASKET |
| 4 | N900A10H* | 55 GALLON DRUM COVER |
| 5 | N656 | DRUM GASKET |
| 6 | N6271* | WASHER |
| 7 | N900H21* | SCREW |
| 8 | N6381* | BALL FLOAT |
| 9 | N900H18* | WIRE CAGE |
| 10 | N900H20* | WIRE CAGE COALESCING FILTER |
| 11 | N900H19* | WASHER |
| 12 | N600H2* | NUT |
| 13 | PQ635 | STANDARD FILTER |
| 14 | - | CONDUCTIVE SEALING WASHER (COMES WITH FILTER) |
| 15 | 2000H10* | WING NUT |
| 16 | N650 | 55-GALLON STANDARD DRUM |
| 17 | N668 | 55-GALLON DRUM DOLLY |
| 18 | N720 | 2" VACUUM HOSE ADAPTOR |
| 19 | N652 | 2" X 10' STANDARD VACUUM HOSE |
| 20 | 12X125C | 1/2" X 12' STANDARD AIR HOSE |
| 21 | N639 | 2" FLOOR TOOL |
| 22 | N693 | 24" CREVICE TOOL |

Items (*) are not sellable on their own.

| Replacement Kits & Maintenance | | |
|--------------------------------|----------|--|
| Item No. | Part No. | Description |
| 1, 3, 6, & 7 | PQNVGA | VACUUM GENERATING ENGINE |
| 3 & 5 | PQNMK55 | 55 GALLON MAINTENANCE KIT |
| 6 - 12 | PQ638 | 20/30/55 GALLON LIQUID SHUT-OFF ASSEMBLY |
| 10 - 12 | PQ638F | WIRE CAGE COALESCING FILTER |
| 13-14 | PQ635H | HEPA FILTER W/ PRE-FILTER BAG |

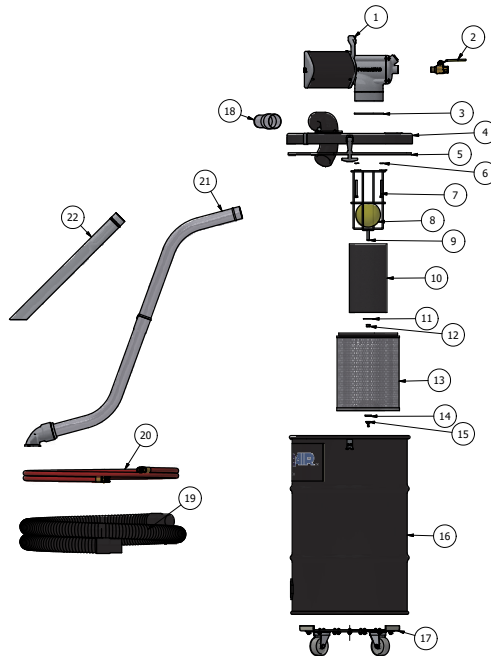

30 GALLON VACUUM KIT WITH 2" INLET (DUST EXTRACTOR)

| Item No. | Part No. | Description |
|----------|-----------|---|
| 1 | PQNVGA | POWERQUAD VACUUM ENGINE (SEE FIGURE 1) |
| 2 | N651 | 1/2 NPT BALL VALVE, BRASS |
| 3 | N7361* | CLOSE NIPPLE |
| 4 | N7362* | REDUCING TEE |
| 5 | N7315* | PUSH TO CONNECT FITTING |
| 6 | N7316* | TUBING |
| 7 | N682 | GASKET |
| 8 | N900A30M* | 20 & 30 GALLON COVER ASSEMBLY |
| 9 | N655 | DRUM GASKET |
| 10 | N6271* | 1/4 INTERNAL TOOTH LOCK WASHER |
| 11 | N900H22* | SCREW |
| 12 | N900H18* | WIRE CAGE |
| 13 | PQ635H | HEPA FILTER |
| 14 | - | CONDUCTIVE SEALING WASHER (COMES WITH FILTER) |
| 15 | 2000H10* | WING NUT |
| 16 | N730X03M* | PULSEAIR MANIFOLD |
| 17 | N715 | 1-1/2" VACUUM HOSE ADAPTOR |
| 18 | AV2005* | LID CLAMP |
| 19 | N737* | PRE-FILTER BAG CLAMP |
| 20 | N635B | PRE-FILTER BAG |
| 21 | N630 | 30 GALLON STANDARD PULSEAIR DRUM |
| 22 | N667 | 20 & 30-GALLON DRUM DOLLY |
| 23 | N652 | 2" X 10' STATIC CONDUCTIVE VACUUM HOSE |
| 24 | 12X125C | 1/2" X 12' STATIC CONDUCTIVE AIR HOSE |

Items (*) are not sellable on their own.

| Replacement Kits & Maintenance | | |
|--------------------------------|----------|--|
| Item No. | Part No. | Description |
| 1, 7, 10, & 11 | PQNVGA | VACUUM GENERATING ENGINE |
| 7 & 9 | PQNMK30 | 20/30 GALLON MAINTENANCE KIT |
| 10-14 | PQ638 | 20/30/55 GALLON LIQUID SHUT-OFF ASSEMBLY |
| 13, 14, & 20 | PQ635H | HEPA FILTER W/ PRE-FILTER BAG |

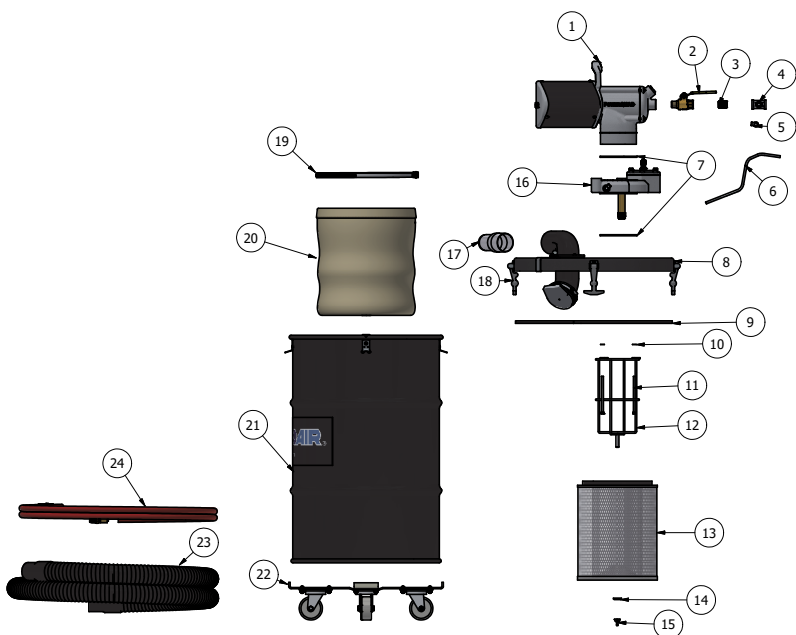

30 GALLON VACUUM KIT WITH 1.5" INLET (ATEX)

| Item No. | Part No. | Description |
|----------|------------|---|
| 1 | PQNVGA | POWERQUAD VACUUM ENGINE (SEE FIGURE 1) |
| 2 | N651 | 1/2 NPT BALL VALVE, BRASS |
| 3 | N682 | GASKET |
| 4 | N900A09M* | 20 & 30 GALLON DRUM COVER |
| 5 | N655 | DRUM GASKET |
| 6 | N6271* | WASHER |
| 7 | N900H21* | SCREW |
| 8 | N6381* | BALL FLOAT |
| 9 | N900H18* | WIRE CAGE |
| 10 | N900H20* | WIRE CAGE COALESCING FILTER |
| 11 | N900H19* | WASHER |
| 12 | N600H2* | NUT |
| 13 | PQ635 | STANDARD FILTER |
| 14 | - | CONDUCTIVE SEALING WASHER (COMES WITH FILTER) |
| 15 | 2000H10* | WING NUT |
| 16 | N630 | 30-GALLON STANDARD DRUM |
| 17 | N667 | 20/30-GALLON DRUM DOLLY |
| 18 | N715 | 1-1/2" VACUUM HOSE ADAPTOR |
| 19 | 2100A02NED | 1-1/2" X 10' STANDARD VACUUM HOSE |
| 20 | 12X125C | 1/2" X 12' STANDARD AIR HOSE |
| 21 | N692 | 1 1/2" FLOOR TOOL |
| 22 | N693 | 24" CREVICE TOOL |

Items (*) are not sellable on their own.

| Replacement Kits & Maintenance | | |
|--------------------------------|----------|--|
| Item No. | Part No. | Description |
| 1, 3, 6, & 7 | PQNVGA | VACUUM GENERATING ENGINE |
| 3 & 5 | PQNMK30 | 20/30 GALLON MAINTENANCE KIT |
| 6 - 12 | PQ638 | 20/30/55 GALLON LIQUID SHUT-OFF ASSEMBLY |
| 10 - 12 | PQ638F | WIRE CAGE COALESCING FILTER |
| 13-14 | PQ635H | HEPA FILTER W/ PRE-FILTER BAG |

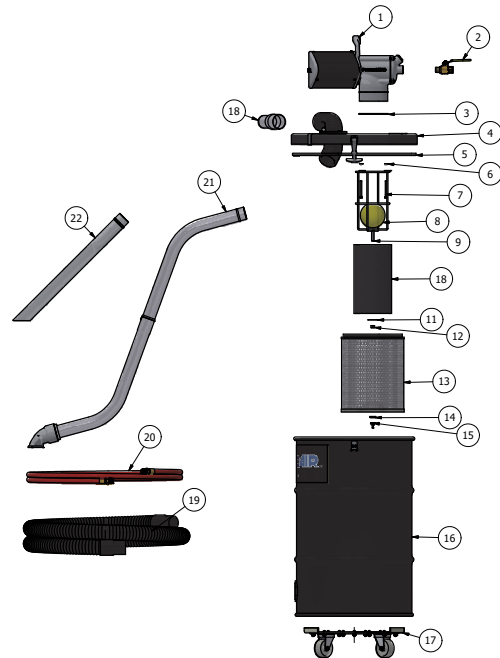

30 GALLON VACUUM KIT WITH 2" INLET (ATEX)

| Item No. | Part No. | Description |
|----------|-----------|---|
| 1 | PQNVGA | POWERQUAD VACUUM ENGINE (SEE FIGURE 1) |
| 2 | N651 | 1/2 NPT BALL VALVE, BRASS |
| 3 | N682 | GASKET |
| 4 | N900A09M* | 20 & 30 GALLON DRUM COVER |
| 5 | N655 | DRUM GASKET |
| 6 | N6271* | WASHER |
| 7 | N900H21* | SCREW |
| 8 | N6381* | BALL FLOAT |
| 9 | N900H18* | WIRE CAGE |
| 10 | N900H20* | WIRE CAGE COALESCING FILTER |
| 11 | N900H19* | WASHER |
| 12 | N600H2* | NUT |
| 13 | PQ635 | STANDARD FILTER |
| 14 | - | CONDUCTIVE SEALING WASHER (COMES WITH FILTER) |
| 15 | 2000H10* | WING NUT |
| 16 | N630 | 30-GALLON STANDARD DRUM |
| 17 | N667 | 20/30-GALLON DRUM DOLLY |
| 18 | N720 | 2" VACUUM HOSE ADAPTOR |
| 19 | N652 | 2" X 10' STANDARD VACUUM HOSE |
| 20 | 12X125C | 1/2" X 12' STANDARD AIR HOSE |
| 21 | N639 | 2" FLOOR TOOL |
| 22 | N693 | 24" CREVICE TOOL |

Items (*) are not sellable on their own.

| Replacement Kits & Maintenance | | |
|--------------------------------|----------|--|
| Item No. | Part No. | Description |
| 1, 3, 6, & 7 | PQNVGA | VACUUM GENERATING ENGINE |
| 3 & 5 | PQNMK30 | 20/30 GALLON MAINTENANCE KIT |
| 6 - 12 | PQ638 | 20/30/55 GALLON LIQUID SHUT-OFF ASSEMBLY |
| 10 - 12 | PQ638F | WIRE CAGE COALESCING FILTER |
| 13-14 | PQ635H | HEPA FILTER W/ PRE-FILTER BAG |

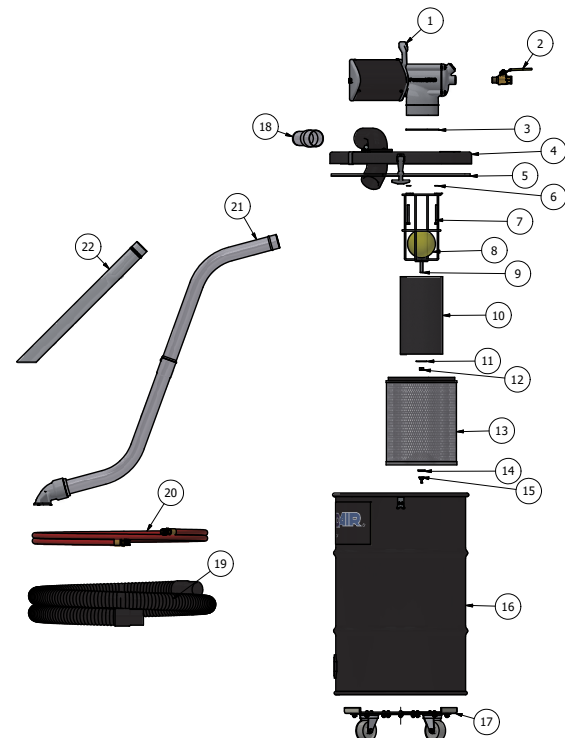

PRODUCT SCHEMATICS

55 GALLON VACUUM KIT WITH 1.5" INLET (ATEX)

| Item No. | Part No. | Description |
|----------|------------|---|
| 1 | PQNVGA | POWERQUAD VACUUM ENGINE (SEE FIGURE 1) |
| 2 | N651 | 1/2 NPT BALL VALVE, BRASS |
| 3 | N682 | GASKET |
| 4 | N900A10H* | 55 GALLON DRUM COVER |
| 5 | N656 | DRUM GASKET |
| 6 | N6271* | WASHER |
| 7 | N900H21* | SCREW |
| 8 | N6381* | BALL FLOAT |
| 9 | N900H18* | WIRE CAGE |
| 10 | N900H20* | WIRE CAGE COALESCING FILTER |
| 11 | N900H19* | WASHER |
| 12 | N600H2* | NUT |
| 13 | PQ635 | STANDARD FILTER |
| 14 | - | CONDUCTIVE SEALING WASHER (COMES WITH FILTER) |
| 15 | 2000H10* | WING NUT |
| 16 | N650 | 55-GALLON STANDARD DRUM |
| 17 | N668 | 55-GALLON DRUM DOLLY |
| 18 | N715 | 1-1/2" VACUUM HOSE ADAPTOR |
| 19 | 2100A02NED | 1-1/2" X 10' STANDARD VACUUM HOSE |
| 20 | 12X125C | 1/2" X 12' STANDARD AIR HOSE |
| 21 | N692 | 1 1/2" FLOOR TOOL |
| 22 | N693 | 24" CREVICE TOOL |

Items (*) are not sellable on their own.

| Replacement Kits & Maintenance | | |
|--------------------------------|----------|--|
| Item No. | Part No. | Description |
| 1, 3, 6, & 7 | PQNVGA | VACUUM GENERATING ENGINE |
| 3 & 5 | PQNMK55 | 55 GALLON MAINTENANCE KIT |
| 6 - 12 | PQ638 | 20/30/55 GALLON LIQUID SHUT-OFF ASSEMBLY |
| 10 - 12 | PQ638F | WIRE CAGE COALESCING FILTER |
| 13-14 | PQ635H | HEPA FILTER W/ PRE-FILTER BAG |

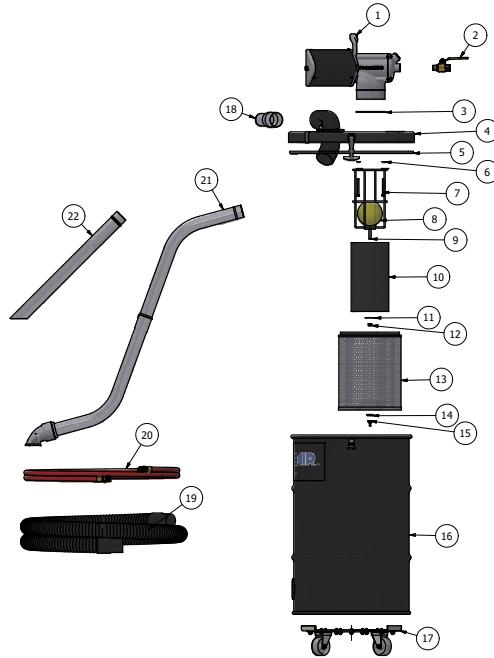

55 GALLON VACUUM KIT WITH 2" INLET (ATEX)

| Item No. | Part No. | Description |
|----------|-----------|---|
| 1 | PQNVGA | POWERQUAD VACUUM ENGINE (SEE FIGURE 1) |
| 2 | N651 | 1/2 NPT BALL VALVE, BRASS |
| 3 | N682 | GASKET |
| 4 | N900A10H* | 55 GALLON DRUM COVER |
| 5 | N656 | DRUM GASKET |
| 6 | N6271* | WASHER |
| 7 | N900H21* | SCREW |
| 8 | N6381* | BALL FLOAT |
| 9 | N900H18* | WIRE CAGE |
| 10 | N900H20* | WIRE CAGE COALESCING FILTER |
| 11 | N900H19* | WASHER |
| 12 | N600H2* | NUT |
| 13 | PQ635 | STANDARD FILTER |
| 14 | - | CONDUCTIVE SEALING WASHER (COMES WITH FILTER) |
| 15 | 2000H10* | WING NUT |
| 16 | N650 | 55-GALLON STANDARD DRUM |
| 17 | N668 | 55-GALLON DRUM DOLLY |
| 18 | N720 | 2" VACUUM HOSE ADAPTOR |
| 19 | N652 | 2" X 10' STANDARD VACUUM HOSE |
| 20 | 12X125C | 1/2" X 12' STANDARD AIR HOSE |
| 21 | N639 | 2" FLOOR TOOL |
| 22 | N693 | 24" CREVICE TOOL |

Items (*) are not sellable on their own.

| Replacement Kits & Maintenance | | |
|--------------------------------|----------|--|
| Item No. | Part No. | Description |
| 1, 3, 6, & 7 | PQNVGA | VACUUM GENERATING ENGINE |
| 3 & 5 | PQNMK55 | 55 GALLON MAINTENANCE KIT |
| 6 - 12 | PQ638 | 20/30/55 GALLON LIQUID SHUT-OFF ASSEMBLY |
| 10 - 12 | PQ638F | WIRE CAGE COALESCING FILTER |
| 13-14 | PQ635H | HEPA FILTER W/ PRE-FILTER BAG |

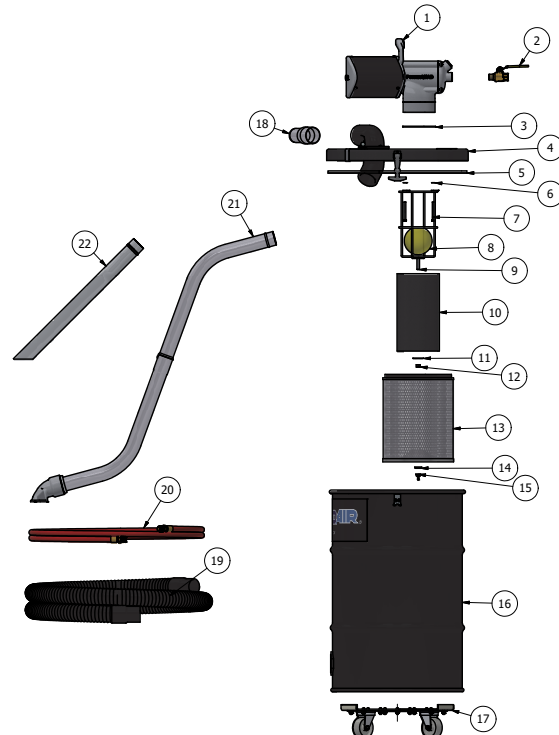

WARRANTIES

WARRANTIES AND WARRANTY PERIODS

Guardair products listed below are covered under the following WARRANTIES along with their respective WARRANTY PERIODS:

PowerQUAD Standard, NED, ATEX Certified, PULSEAIR Equipped Pneumatic Vacuums and Dust Extractors

Forever Warranty – Forever Warranty Period

Vacuum Consumables, Accessories and Attachments

Limited Warranty – 90 Day Warranty Period Vacuum consumables include filters, exhaust silencers, and cover gaskets. Accessories include air supply hose, vacuum hose, and other attachments.

FOREVER WARRANTY

Guardair Corporation (“Guardair”) warrants its PowerQUAD Standard, NED, ATEX Certified, PulseAir Equipped Pneumatic Vacuums and Dust Extractors are free from defects in materials and workmanship for as long as the original end-user purchaser owns the product, except as provided below. Guardair will, at its option, repair or replace with a comparable product, any product, part, or component that fails under normal use because of such defect.

This Forever Warranty does not apply to damage caused by the carrier; normal wear and tear; deterioration due to solvents, corrosives, environmental conditions, or harsh vacuumed material; soiling, saturation, or perforation of filters or exhaust silencers; consumable components; modifications to the product; attachments to the product not sold by Guardair; or any product not installed, used, or maintained in accordance with the foregoing and other published Guardair instructions and warnings.

This Forever Warranty covers the original purchase of a new PowerQUAD Standard, NED, ATEX Certified, PulseAir Equipped Pneumatic Vacuums and Dust Extractors by an end-user purchaser for normal industrial or commercial use, and only when installed and used as specified and in accordance with published operating instructions and within all applicable regulatory rules, limits, and guidelines.

Guardair's sole obligation and the end-user purchaser's exclusive remedy under this Forever Warranty shall be limited to the repair or replacement, of product or components. In no event shall Guardair be responsible for special, consequential, or incidental damages arising out of a claim for defective product or failure of warranty. All labor and material costs of repair or replacement under this Forever Warranty shall be the responsibility of Guardair. Shipping costs to and from the end-user purchaser associated with repair or replacement under this Forever Warranty shall be the responsibility of Guardair for a period of One Year after date of purchase.

To obtain service under this Forever Warranty, the end-user purchaser must contact the Distributor from whom the product was purchased or contact Guardair directly. The end-user purchaser must provide a reasonable opportunity for inspection and investigation of the claim, prior to any repairs or alteration to the product. Until the claim is resolved, the end-user purchaser must discontinue use of the product if continued use creates or exacerbates problems associated with, or incidental to, the defect.

Proof of purchase will be verified by the end-user purchaser and applicability of the Forever Warranty will be determined by Guardair. Guardair at its sole discretion will determine whether to repair or replace defective parts or products. Written return authorization from Guardair must be obtained before any product can be returned. Any unauthorized repairs performed by parties other than Guardair or its authorized Distributors will void this Forever Warranty.

LIMITED WARRANTY

Guardair Corporation (“Guardair”) warrants that, under normal use, our products are free from defects in materials or workmanship during the Limited Warranty Period. Starting from the date of purchase and during the Limited Warranty Period, Guardair will, at our sole discretion, repair or replace defective parts or products. This Limited Warranty extends only to products that are purchased either directly from Guardair Corporation or from an authorized Guardair Distributor. Furthermore, the Limited Warranty extends only to products which are used for their intended purpose. This Limited Warranty does not extend to any product which has been misused, or that has been damaged from accident or mistreatment, from the use of parts not supplied by Guardair, or from modification or servicing of the product by anyone other than Guardair or its authorized Distributor.

Guardair's sole obligation and the end-user purchaser's exclusive remedy under this Limited Warranty shall be limited to the repair or replacement, of product or components. In no event shall Guardair be responsible for special, consequential, or incidental damages arising out of a claim for defective product or failure of warranty. All labor and material costs of repair or replacement under this Limited Warranty shall be the responsibility of Guardair. Shipping costs to and from the end-user purchaser associated with repair or replacement under this Limited Warranty shall be the responsibility of Guardair during the Limited Warranty Period.

To obtain service under this Limited Warranty, the end-user purchaser must contact the Distributor from whom the product was purchased or contact Guardair directly. The end-user purchaser must provide a reasonable opportunity for inspection and investigation of the claim, prior to any repairs or alteration to the product. Until the claim is resolved, the end-user purchaser must discontinue use of the product if continued use creates or exacerbates problems associated with, or incidental to, the defect.

Proof of purchase will be verified by the end-user purchaser and applicability of the Limited Warranty will be determined by Guardair. Guardair at its sole discretion will determine whether to repair or replace defective parts or products. Written return authorization from Guardair must be obtained before any product can be returned. Any unauthorized repairs performed by parties other than Guardair or its authorized Distributors will void this Limited Warranty.

THE FOREGOING WARRANTIES OF GUARDAIR CORPORATION ARE IN LIEU OF ALL OTHER WARRANTIES OF GUARDAIR CORPORATION, EXPRESSED OR IMPLIED, WITH RESPECT TO THE PRODUCT, INCLUDING WITHOUT LIMITATION WARRANTIES OF MERCHANTABILITY OR FITNESS FOR A PARTICULAR PURPOSE. GUARDAIR CORPORATION EXPRESSLY DISCLAIMS ALL WARRANTIES NOT STATED IN THESE WARRANTIES. IN NO EVENT SHALL GUARDAIR CORPORATION BE LIABLE FOR ANY INDIRECT, SPECIAL OR CONSEQUENTIAL DAMAGES IN CONNECTION WITH OUR PRODUCTS.

GUARDAIR CORPORATION ASSUMES NO RESPONSIBILITY OR LIABILITY WHATSOEVER FOR ANY PRODUCTS WHICH ARE ALTERED OR MODIFIED IN ANY FASHION, OR WHICH ARE USED IN A MANNER FOR WHICH THEY WERE NOT ORIGINALLY INTENDED.

THE PURCHASER MAY HAVE CERTAIN STATUTORY RIGHTS, AS A CONSUMER, OR OTHERWISE, TO WHICH THE EXCLUSIONS SET FORTH IN THIS LIMITED WARRANTY DO NOT APPLY.

THESE WARRANTIES ONLY APPLY TO PURCHASES WITHIN, AND PRODUCTS USED WITHIN THE UNITED STATES AND CANADA.



N900A38
05.05.25

GUARDAIR®

47 Veterans Drive • Chicopee, MA 01022-1062

Toll-Free: 800-482-7324 | Local: 413-594-4400 | Fax: 413-594-4884

Email: info@guardair.com • guardair.com

